

WIRELESS POWER TRANSFER (WPT) FOR ELECTRIC VEHICLE (EV) BATTERY CHARGING BY MAGNETIC RESONANCE COUPLING (MRC)

Kuldeep Sudhakar Kapse
 VLSI & EMBEDDED SYSTEM
 G.H.R.I.E.T. Wagholi, Pune
 mekuldeepkapse@gmail.com

ABSTRACT:

This paper presents about the wireless power transfer for the Electric Vehicle(EV) battery charging it helps in the reducing the size of the electric vehicle car battery which result in the reduction of the price of the battery required for the EV. It help in the minimization of the Electric Waste production after the cable of the plug-in vehicle or Hybrid vehicle it is environmental friendly as the reduction of the battery required result in the low e-waste generation, this is done with the help of the two coils one at the transmitting end and one at the receiving end at the EV these system are electrically isolated but magnetically coupled, optimization of the power is done with the help of the resonating the two coils so that the power transfer efficiency is more and losses is reduced.

Keyword: Wireless Power Transfer, Electric Vehicle, Magnetic Resonance Coupling.

I. INTRODUCTION:

After Wireless communication there is the new research going on the Wireless Power Transfer(WPT) mostly for the hand held gadgets like the Mobile, Tablet ,I-pad, I-phone which required continuous power supply for their operation as advancement in technology there are complex circuitry can fix in the small area and power required by such devices is also more and providing the power to such device also big challenge it can be overcome by the use of the WPT technique it helps in the reduction of battery size which result in the extra space for the new hardware so that the performance of the device is increases. This technique can be implemented on the EV, Hybrid Vehicle battery charging this helps in the reduction of the cost of the battery used for the EV, as less battery is needed as we have the WPT System which can charge battery when they are drained. [1-3]

There are so many topology for the wireless power transfer like depending on the arrangement of coil and capacitor basically that are divided into four ie.

A. series-series (ss) B. series-parallel(sp) C. parallel-series(ps) D. parallel-parallel(pp) in ss topology both primary side coil and capacitor are connected and in secondary side coil and capacitor are connected in series and both coil are magnetically coupled to each other and in sp topology primary coil and primary capacitor connected in series but at secondary coil and capacitor are connected in the parallel and similarly with other topology they have their own importance in the WPT system. These all are shown in the fig.1

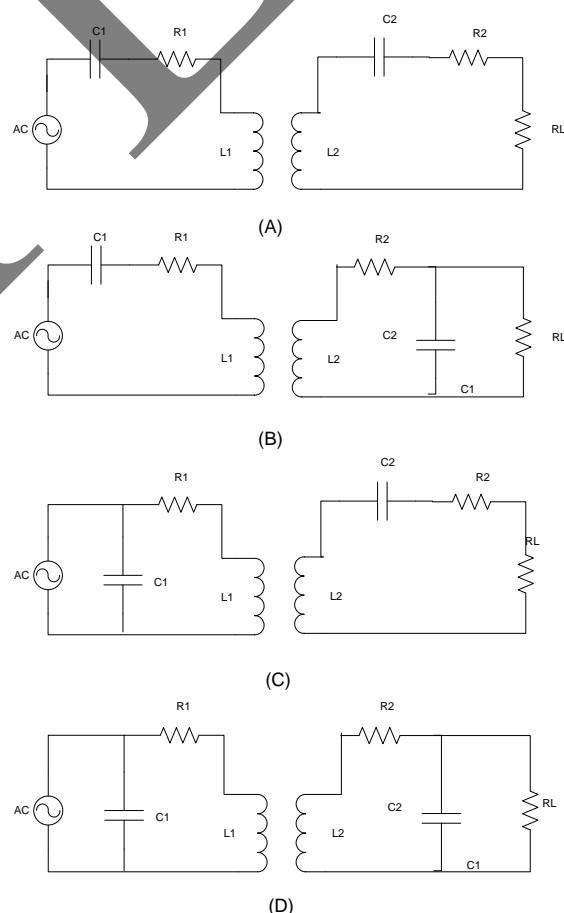

Fig.1 Different topologies of the circuits depending upon the combination of series & parallel connection

This topology helps us in the mathematical calculation of the different parameter of the circuit and the variation of the impedance of the circuit depending on the load as hear load is the battery of the EV. This is varying depending on the whether the battery is charging or the discharging.

II. LITERATURE REVIEW:

Wireless power transfer can be done by the various methods depending on the throughput we required like the power we want at the receiving side and current and the efficiency of the design.

Inductively coupled power transfer is the one of the method for the WPT for the EV, here transmitting and the receiving coil are mutually coupled with each other as they are mutually coupled with each other the coupling coefficient (k) depend on the distance between the two coil and also their self inductance $L1$ & $L2$.

$$k = \frac{M}{\sqrt{L1 L2}}$$

In this both coil are coupled inductively for the maximum power transfer both primary and secondary must be have resonant frequency so that the losses in the winding is minimized as both coil have their own resistance and their reflected impedance also reduce the performance of the design. Zero Phase Angle (ZPA) concept is introduce in this design to reach maximum power transfer ie. The phase difference is cause because of the variation of the load and the variation between the coupling between the primary and the secondary.

Loosely-coupled (LC) wireless power transfer is also one of the ways for WPT for the wide range of the electronics consumer appliances like the Mobile hand sate and other applications LC WPT basically work on the magnetically coupled resonant coil system which is the heart of the LC WPT system. In this power transfer is based on the Faraday's Law and the Lenz's Law says that time varying current in the one loop result in the time variation of Magnetic flux in the loop and surrounding because of this time varying Magnetic flux the other conducting coil place in the vicinity of this flux will induced an opposite e.m.f. in the other loop this loop produces the current such that it opposes the cause of its own.i.e. changing magnetic flux. For this happen the coupling coefficient must be greater than zero and less than one ($0 < k < 1$)[4] this can be achieved by the proper alignment of the coil and choosing the proper frequency for the

variation of current in the primary coil so that Magnetic flux produce by this is maximum at rated value. Flow of the power is shown in the model that shown in the Fig.2 LC-WPT power handling high-level circuit model the challenge of this is variation of the load as load is the battery and it is the function of the time varying charge state as battery is charged and discharge.

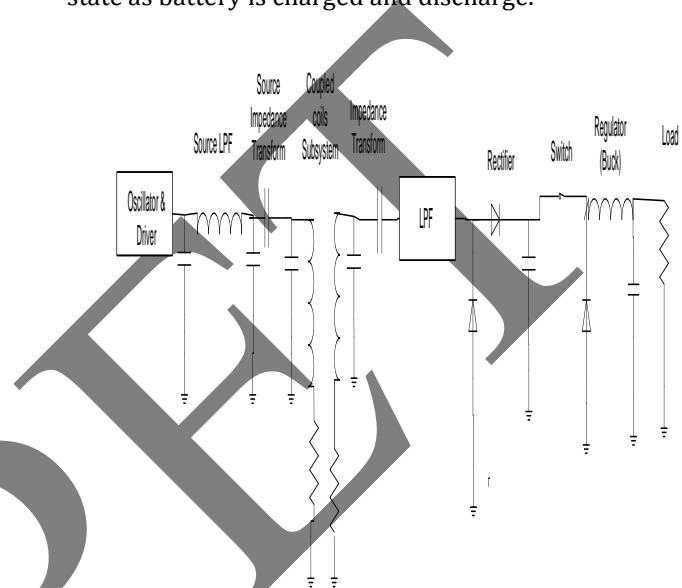

Fig.2 Model LC WPT Power handling high-level Model.

WPT system with inductive coupling are used to charge the battery pack of the electric vehicle they are basically consist of the coils which are connected to the power supply at the transmitting end of the power supply this AC power is converted into the DC power supply with the help of the rectifier , after the DC with ripple containing signal is filtered and constant DC voltage is get, this DC signal is the converted into the high frequency AC signal this is done with the help of the H-bridge this high frequency AC signal is given to the Impedance Matching Network (IMN)[5]. which matches the impedance of the circuit which help in the tuning of the circuit at the particular frequency so that the power transfer is maximum at the particular frequency at the receiving end which is at the EV will receive the power and this received power is then given to the IMN at the receiving end at EV then this given to the receiving rectifier and ripple in this is removed with the help of the chopper this all is represented in the fig.3

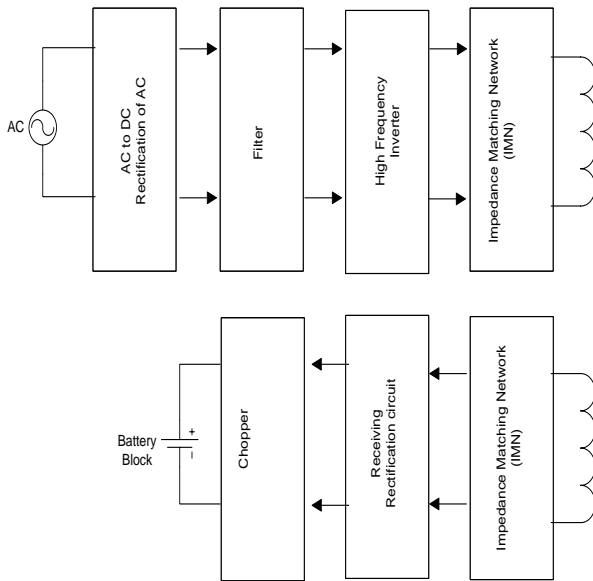

Fig.3. Block diagram representation of the WPT.

The most important block is the IMN (Impedance Matching Network) which is present at both side at transfer side and the receiving side as due to miss alignment and the variation of the battery resistance the impedance is always changing as not equal so for making this happen we need the IMN at both end for the optimal power transfer, High frequency inverter is needed at both end as for the battery

Charging we need the DC power supply and for the WPT we need the high oscillating power supply so that the energy transfer with the magnetic field is done with high efficiency it is happen because of the high frequency H-Bridge[6] by which inversion of the DC power with high frequency is possible.

III. PROPOSED WORK:

Here wired charging cable is replaced by the wireless power transfer coil that are activated when vehicle come in the vicinity of the WPT platform for electric vehicle as shown in the fig.4 here high frequency power inverter convert low frequency utility to high frequency AC power. Resonance magnetic field generated in the transmitting resonator coil transfer the power to the receiving resonator coil. This received power at the secondary resonator coil then rectifies to charge the battery

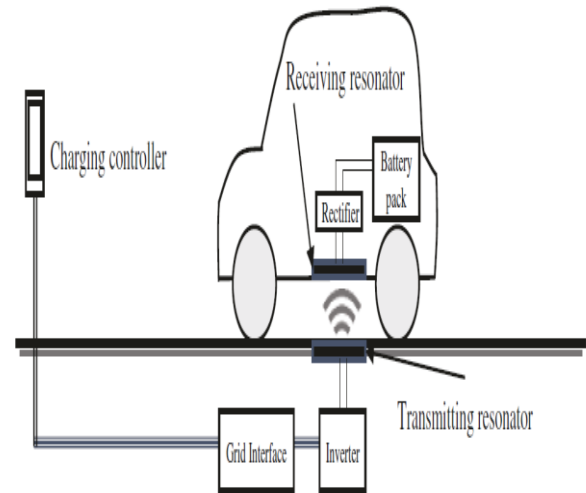

Fig.4 Stationary WPT for Electric Vehicle Charging.

Power from the grid or transmission line are brought near wireless charging point station. AC power from the transmission line then converted in the DC power as there is the generation of the high frequency AC as DC to RF (Radio Frequency) conversion is done their [7] . Now we have the high frequency AC power for the transmission these are shown in the fig.5 Block diagram of WPT system. For the optimal power transfer system there is requirement of the Impedance Matching Network (IMN) which matches the impedance of the circuit as two coils for the maximum power transfer from one network to another network which is physically not connected but magnetically coupled [8]. Source resonating circuit is the copper coil and the capacitor so that the tuning frequency of two coil are matched for the optimal power transfer from the transmission circuit and receiving circuit. In Electric Vehicle battery is the load and This load is not constant as Electric Vehicle run battery are discharge and its load is also varying and there is the big problem for the matching both loads of the source circuit of the transmitter and the load circuit of the receiving network.

In India there is the transmission of the power for the household or industrial purpose are 230 V with 50 Hz and 450 V with 50Hz frequency respectively. Requirement for our proposed design is at Radio Frequency (RF) this can be achieved by the making AC to DC this is known as the rectifier. Rectifier circuit is made up from diodes to rectify AC signal and then make it repel free which can be achieve by the proper selection of capacitor and inductor at the EV charging point centre

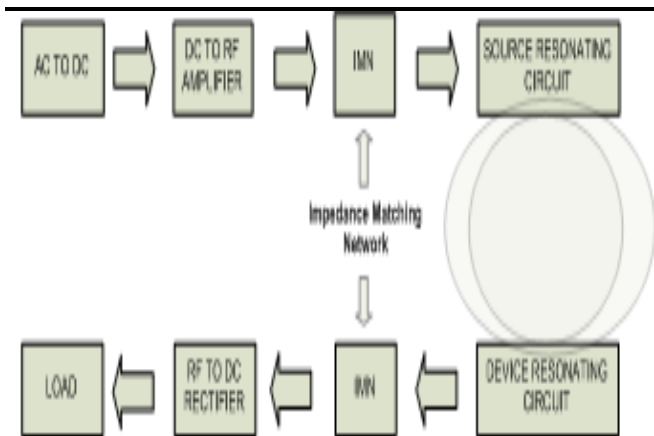

Fig.5 Block diagram of WPT system.

DC to RF ie. Higher frequency conversion is important for the transmission of the power wirelessly there is formation of the higher oscillating current which help in the optimal power transfer from the transmission point to the receiving point at the EV receiver. As for increasing the efficiency we want the high quality factor of the coil this can be achieve by the increasing frequency and decreasing resistance of the coil resistance can be decreases by using high conducting metal like copper. In WPT the frequency is in 100 of kilo Hz or in MHz.

Impedance matching network(IMN) this can be also known as the tuning of the network to get the optimal power at the receiver this can be achieved by choosing the proper component rating. At particular distance where coupling coefficient equal to the critical coupling. The equivalent load impedance is depending on the state of charge of the Electric Vehicle battery which is varying with the charging.

The coils play an important role in WPT design stages. For WPT coils, there are two performance indices quality factor and electromagnetic coupling between transmitter and receiver[8]. The quality factor can be improved by decreasing the AC resistance (skin and proximity losses) of the coil while maintaining high inductance. But, enhancement of the electromagnetic coupling is severely limited by the misalignment and distance between coils which cannot be compromised due to most application constrains. Instead, coupling variation can be optimized by choosing appropriate coil structure for a particular position displacement profile.

There have been a number of studies which addressed the losses related to resonators. Several optimized resonator designs have been proposed.

IV. CONCLUSION:

From the above discussion and the previous work we can say that the wireless power transfer of power is possible. Provided that the distance of the power transfer from the transmitter and the receiver is as per the mention specification alignment of the coil is maximum for the efficient transfer of power .Resonating frequency must be selected such that the power transfer is maximum, impedance matching network is design proper for the matching impedances of receiving coil & transmitting coil as state of charge of battery is vary and the cell internal resistance also vary that's are the field we want to concentrate for optimal power transfer.

V. REFERENCES:

- [1] Patent US 119732 "Apparatus for transmitting Electrical Energy". Patented Dec. 1, 1914
- [2] Dr. Morris Ksler WiTricity Corporation ,2013 " Highly Resonant Wireless Power Transfer : Safe, Efficient and Over Distance"
- [3] Rajakaruna S.; Garcia-Cerrada, A; Ghosh, A(Ads), "Plug In Electric Vehicles in Smart Grids Integration Techniques" ISBN: 978-981-287-298-2
- [4] Kamil A Grajski ;Ryan Tseng and Chuck Wheatly Qualcomm Incorporated San Diego,CA, USA "Loosely-Coupled Wireless Power Transfer: Physics, Circuits, Standards" IEEE IMS2012 LC WPT Technical Paper DOI: 10.1109/IMWS.2012.6215828.
- [5] Teck Chuan Beh, Takehiro Imura , Masaki Kato, Yoichi Hori " Basic Study of Improving Efficiency of Wireless Power Transfer via Magnetic Resonance Coupling Based on Impedance Matching"2010 IEEE.
- [6] Giuseppe Buja , Manuele Bertoluzzo and Kishore N. Mude "Design and Experimentation of WPT Charger for Electric City-Car" IEEE Transaction on Industrial Electronics. DOI 10.1109/TIE.2015.2455524
- [7] Chi-kwan Lee, Sitthisak Kiratipongvoot, Siew-Chong Tan. "High-Frequency-Fed Unity Power-Factor AC-DC Power Converter with One Switching Per Cycle" IEEE Transactions on Power Electronics DOI: 10.1109/TPEL.2014.2330631
- [8] Zhen Zhang , K. T. Chau , Chunhua Liu , Fuhua Li ,T. W. Ching "Quantitative Analysis of Mutual Inductance for Optimal Wireless Power Transfer Via Magnetic Resonant Coupling". IEEE Transactions on Magnetics Vol.50, NO.11 Nov. 2014.