

IMPLEMENTATION OF SOLAR FRIDGE WITH FAST CHILLING APPLICATIONS WITH VOLTAGE MONITORING

GAYATRI L. ADVANT

M.E Student. Electronics and Telecommunication Department, Deogiri Institute of Engineering and
Management Studies, Aurangabad (MS), India

ASSISTANT PROF. A.K PATHRIKAR

Professor, Electronics and Telecommunication department, Deogiri Institute of Engineering and Management
Studies, Aurangabad (MS), India

ABSTRACT:

In this paper we are mainly focusing on a solution to control this problem we have focused on refrigerators which releases CFC's. Here we are designing a mini solar based refrigerator which is cheaper as well as eco-friendly. Here we are using Micro controller (AT89S52) allows dynamic and faster control. Liquid crystal display (LCD) makes the system user-friendly. In this paper we are using solar panels for charging a Lead Acid Battery (12V, 1.2 Amp hrs), a peltier thermoelectric device when connected to battery generates cool effect and hot effects depending on the mode required by the user. Since we are using this for fridge we need only cool mode. A peltier thermoelectric device is connected to the battery to generate cooling effect. We need to display the voltage for that we are using ADC0808 which is given to the controller. For this ADC we are giving a clock pulses through 555 timer to perform its operation.

This paper uses regulated 5V; 500mA power supply. A 7805 three terminal voltage regulator is used for voltage regulation. Bridge type full wave rectifier is used to rectify the ac output of secondary of 230/12V step down transformer.

KEYWORDS: Solar energy, peltier effect, thermoelectric cooling and heating, etc

I. INTRODUCTION:

A solar-powered refrigerator is a refrigerator which runs on energy directly provided by sun, and may include photovoltaic or solar thermal energy. Solar-powered refrigerators are able to keep perishable goods such as meat and dairy cool in hot climates, and are used to keep much needed vaccines at their appropriate temperature to avoid spoilage. Solar-powered refrigerators may be most commonly used in the developing world to help mitigate poverty and change. There is environmental concern regarding conventional refrigeration technologies including contribution to ozone layer depletion and global warming.

Refrigerators which contain ozone depleting and global warming substances such as chlorofluorocarbons (CFCs), in their insulation foam or their refrigerant cycle, are the most harmful. After CFCs were banned in the 1980s, they were replaced with substances such as hydrochlorofluorocarbons (HCFCs), which are ozone-depleting substances and hydrofluorocarbons (HFCs). Both are environmentally destructive as potential global warming chemicals. If a conventional refrigerator is inefficient or used inefficiently, it will also contribute more to global warming than a highly efficient refrigerator. The use of solar energy to power refrigeration strives to minimize the negative impacts refrigerators have on the environment.

II. RELATED WORK:

Yasmina Boukhchanna represented a general dynamic model for the study and optimization of reversed cycle thermal machines with three heat reservoirs is presented. The model is based on the First and Second Laws of Thermodynamics, heat transfer equations at finite thermal source and sink capacities, and entropy generation terms in order to consider the internal and external irreversibilities of the cycle. The proposed model is applied to an irreversible absorption machines for which several constraints are imposed. Some results generated by the model when applied to refrigeration machines are presented. They point out interesting results regarding the limits of the variation range for the model variables under different operating conditions and also for different variation laws for the internal entropy generation term. As a result, the model is expected to be a useful tool for simulation, design, and optimization of solar collector based energy systems.

D.C Martins, A.J. Andrale has given the analysis of a PV solar energy electronics processing system, operating at the maximum power point (MPP) for commercial refrigerator supply applications is presented in this paper. The refrigerator is fed from a battery bench using two

electronics processing stages. The first one is a step-up push-pull converter that is responsible for the dynamic of the refrigerator and the DC bus voltage control, and the second stage is a full-bridge voltage source inverter with three levels PWM modulation. A closed-loop voltage is used to control the step-up stage, and a closed-loop current to control the compressor starting current. The main features of this system are: simple control strategy, robustness, low harmonic distortion of the load voltage, and natural isolation. The principle of operation, design procedure and experimental results are presented

Shumgan Chaen, Dan Xie presented a solar energy semiconductor cooling box is presented in the paper. The cooling box is compact and easy to carry, can be made a special refrigeration unit which is smaller according to user needs. The characteristics of the cooling box are its simple use and maintenance, safe performance, decentralized power supply, convenient energy storage, no environmental pollution, and so on. In addition, compared with the normal mechanical refrigeration, the semiconductor refrigeration system which makes use of Peltier effect does not require pumps, compressors and other moving parts, and so there is no wear and noise. It does not require refrigerant so it will not produce environmental pollution, and it also eliminates the complex transmission pipeline. The concrete realization form of power are "heat - electric - cold", "light - electric - cold", "light - heat - electric - cold". In order to achieve the purpose of cooling, solar cells generate electricity to drive the semiconductor cooling devices. The working principle is mainly photovoltaic effect and the Peltier effect.

C. Del Pero gave the performance of a $4 \times 4 \text{ cm}^2$ Bismuth Telluride based thermoelectric generator with 126 thermocouples connected in series is analyzed experimentally under different environmental conditions. The hot junction of the thermoelectric generator is exposed to solar and candle heat and the cold side is exposed to atmosphere. With the hot junction temperature of 53°C and cold junction temperature of 32°C , the output voltage, current and power are measured as 0.35V, 0.042A and 0.014W respectively. The hot junction of the thermoelectric generator is then exposed to solar concentrator heat and the cold side is exposed to ice. With the hot junction temperature of 100.2°C and cold junction temperature of 2.9°C , the output voltage, and power are measured as 2.96V, 0.1083A and 0.319W respectively. The power output is increased by 30.5%. The power density is $2.11 \mu \text{ Wcm}^{-2} \text{ }^\circ\text{C}^{-1}$

Carlos Ugalde has show that Thermoelectric refrigeration offers advantages (e.g., no moving parts) over other refrigeration technologies. However, because maximum performance (i.e., heat load for a specified temperature drop below ambient temperature or vice

versa) and efficiency (i.e., coefficient of performance) are relatively low, it is important to realize them. It is shown that the cross-sectional area of the semiconductor pellets in a thermoelectric module (TEM) operating in refrigeration mode does not affect its performance or efficiency, but may be sized to tune its operating current and voltage. Then, a procedure is provided to determine the height of the pellets which maximizes performance. Next, it is shown that a range of pellet heights accommodates a specified performance below the maximum one and a procedure is provided to compute that corresponding to maximum efficiency. A thermal resistance boundary condition is applied between the interface in a TEM where Peltier cooling occurs and the control point where it maintains the temperature of a component or medium below ambient temperature. Thermal resistance boundary conditions are also applied between the control point and its local ambient and the interface in a TEM where Peltier heating occurs and its local ambient. The analysis is generalized by using flux-based quantities where applicable and it accounts for the electrical contact resistance at the interconnects in a TEM. Implementations of the optimization procedures are illustrated and the ramifications of the results are discussed.

III. SYSTEM DEVELOPMENT:

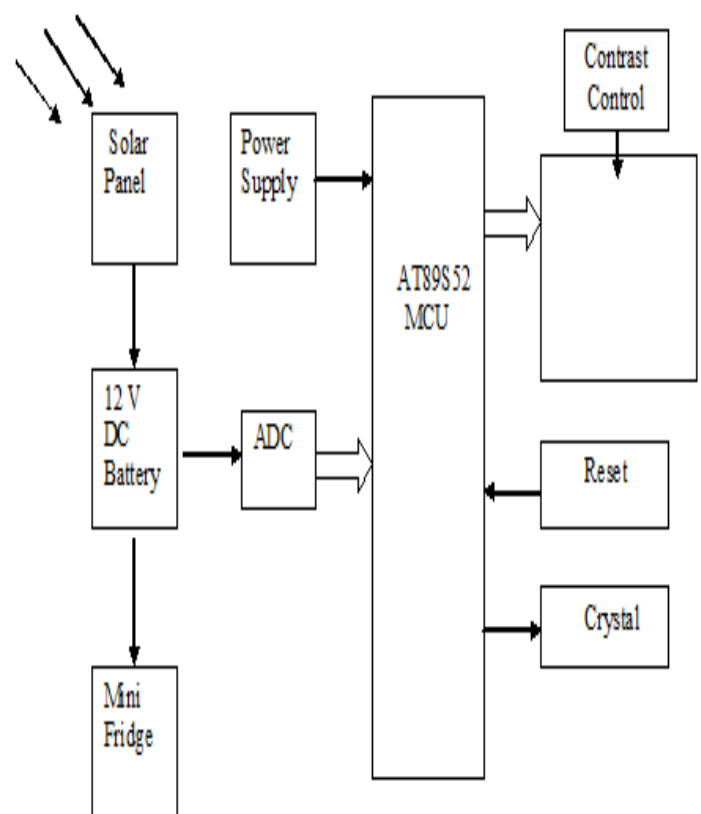

Fig 1: Block diagram

For normal functioning of human beings sufficient, protein, carbohydrate, vitamin and salts are requires which accomplish by balance diet or pills. The people with normal health and their peculiar habits prefer tasteful diet to fulfill the normal functioning of body organs requirement. Another necessity of refrigeration is in the developing of certain scientific equipment and their operation under controlled environment to get reliable results. Many industries like chemical, milk dairy, oil refinery, etc. require low temperature to carry various processes

IV. PERFORMANCE ANALYSIS:

ENERGY OF PHOTON:

A photon is characterized by either a wavelength, denoted by λ or equivalently an energy, denoted by E. There is an inverse relationship between the energy of a photon (E) and the wavelength of the light (λ) given by the equation[10]

$$E=hc\lambda \quad (1)$$

where h is Planck's constant and c is the speed of light. The value of these and other commonly used constants is given in the constants page.

$$h = 6.626 \times 10^{-34} \text{ joules} \quad (2)$$

$$c = 2.998 \times 10^8 \text{ m/s} \quad (3)$$

By multiplying to get a single expression,

$$hc = 1.99 \times 10^{-25} \text{ joules-m} \quad (4)$$

The above inverse relationship means that light consisting of high energy photons (such as "blue" light) has a short wavelength. Light consisting of low energy photons (such as "red" light) has a long wavelength.

When dealing with "particles" such as photons or electrons, a commonly used unit of energy is the electron-volt (eV) rather than the joule (J). An electron volt is the energy required to raise an electron through 1 volt, thus a photon with an energy of $1 \text{ eV} = 1.602 \times 10^{-19} \text{ J}$. Therefore, we can rewrite the above constant for hc in terms of eV:

$$hc = 1.24 \times 10^{-6} \text{ eV-m} \quad (5)$$

Further, we need to have the units be in μm (the units for λ):

$$hc = 1.24 \text{ eV-}\mu\text{m} \quad (6)$$

By expressing the equation for photon energy in terms of eV and μm we arrive at a commonly used expression which relates the energy and wavelength of a photon, as shown in the following equation:

$$E(\text{eV})=1.24\lambda(\mu\text{m}) \quad (7)$$

The exact value of $1 \times 10^6(hc/q)$ is 1.2398 but the approximation 1.24 is sufficient for most purposes.

SPECTRAL IRRADIANCE:

The spectral irradiance as a function of photon wavelength (or energy), denoted by F, is the most common way of characterizing a light source. It gives the power

density at a particular wavelength. The units of spectral irradiance are in $\text{Wm}^{-2}\mu\text{m}^{-1}$. The Wm^{-2} term is the power density at the wavelength $\lambda(\mu\text{m})$. Therefore, the m^{-2} refers to the surface area of the light emitter and the μm^{-1} refers to the wavelength of interest.

In the analysis of solar cells, the photon flux is often needed as well as the spectral irradiance. The spectral irradiance can be determined from the photon flux by converting the photon flux at a given wavelength to W/m^2 as shown in the section on Photon Flux. The result is then divided by the given wavelength, as shown in the equation below.[10]

$$F(\lambda)=\Phi E1\Delta\lambda \text{ in SI units} \quad (1)$$

where in SI units:

$F(\lambda)$ is the spectral irradiance in $\text{Wm}^{-2}\mu\text{m}^{-1}$;

Φ is the photon flux in # photons $\text{m}^{-2}\text{sec}^{-1}$;

E and λ are the energy and wavelength of the photon in joules and meters respectively

RADIANT POWER DENSITY:

The total power density emitted from a light source can be calculated by integrating the spectral irradiance over all wavelengths or energies[10]

$$H=\int_{\infty}^{\infty} F(\lambda)d\lambda \quad (2)$$

Where:

H is the total power density emitted from the light source in W m^{-2} ;

$F(\lambda)$ is the spectral irradiance in units of $\text{Wm}^{-2}\mu\text{m}^{-1}$; and $d\lambda$ is the wavelength.

Design consideration for thermoelectric refrigerator (VOX mini fridge)

- Volume of Freezer section
- Volume of Ref-section
- Condensor tube inner diameter
- Capillar tube inner
- Refrigerant used
- Temp required in F-section
- Temp required in R-section

PASSIVE HEAT LOAD:

The passive heat load for the unit was first calculated based upon a 25cm x 25cm x 25cm interior volume. Two inches of polystyrene insulated was assumed ($k=0.027\text{w/mK}$). Also included were a rubber seal on the door which was 50 cm^2 in area.

Where: q_{tot} is the heat transfer in watts, k is the resistance to heat transfer, and k_{rubber} is 0.014w/mK . ΔT is assumed to be $20 \text{ }^\circ\text{C}$ and Δx is 0.50m .

This gives a q_{tot} of 10 W.

ACTIVE HEAT LOAD:

The active heat load is the equivalent of the cooling power that the unit will need to provide when the sample at

room temperature is placed in the container. It was decided that one liter of water at room temperature would be the test sample for which all calibration and calculations would be made. The time to cool this load from 25 °C to 5 °C was determined to be 1 hour, or 3600 seconds.

If the Cp of water is 4.14 KJ/kg*K, then $Q = 82800J$ and dividing by 3600s to get power (W), $Qdot = 23 W$ for the active heat load. Therefore, the total load is $23 + 11 W = 34 W$ of power required. This assumes that there is no thermal resistance between the sample and the air in the unit. This may be an incorrect assumption but it does overestimate the cooling load

DESIGN CONSIDERATIONS:

- 1: Understand the load: You must determine how much work the thermoelectric system must do to achieve the goal.
- 2: Select your thermoelectric device: Choose a thermoelectric device that can do the work you have determined while operating in the worst case scenario. Choose the module that can do this while operating in the "sweet spot" of 70-80% of I_{max}.
- 3: Select the level of corrosion, and dielectric protection: Choose the level of protection needed for your operating conditions.
- 4: Select your heat sink: Determine what heat sink performance is needed to achieve the goal, and source the proper device.
- 5: Assemble your system: A properly designed and assembled system will provide even clamping force, good thermal interface, proper sized thermoelectric module, adequate heat sinking, proper corrosion resistance

Table 1: Comparison between AC operated fridge & solar fridge

PARAMETRS	AC OPERATED FRIDGE	SOLAR FRIDGE
Cost	Costly	Low cost
Power requirement	500 watt	150 watt
Power supply	Required	Not required
Efficiency	Moderate	Highly efficient
Space required	Moderate	Less

RESULT:

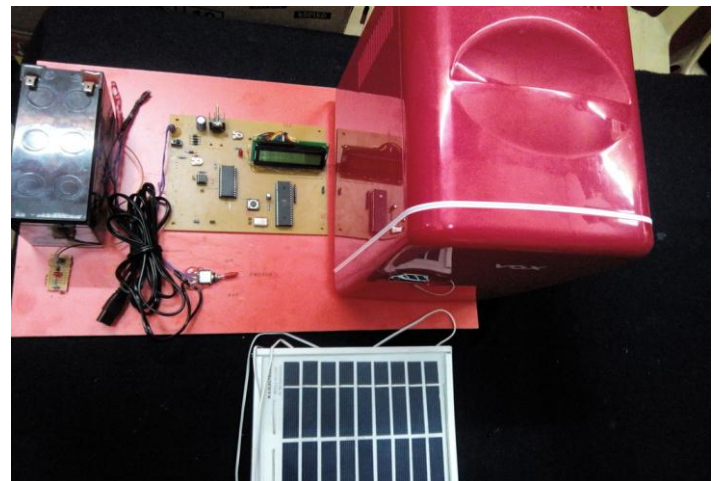

Fig 2: Result

V. CONCLUSION

Thus the paper concludes that solar energy systems must be implemented to overcome increasing electricity crisis. In this work, a portable solar operated system unit was fabricated and tested for the cooling and heating purpose. The system was designed based on the principle of a thermoelectric module to create a hot side and cold side. The cold side of the thermoelectric module was utilized for cooling purposes whereas the rejected heat from the hot side of the module was eliminated using heat sinks and fans. And hot side of the thermo electrical module was utilized for heating purpose. In order to utilize renewable energy, solar energy was integrated to power the thermoelectric module in order to drive the system. Furthermore, the solar thermoelectric cooling and heating system avoids any unnecessary electrical hazards and proves to be environment friendly.

The paper is based on solar energy, thus solar energy is very necessary for the working of our project. But in rainy season it cannot be possible to charge battery from solar. This is the limitation of our project but this problem can be solved by giving direct current supply

VI. REFERENCES:

- [1] "Performance Evaluation of a Thermoelectric Refrigerator", Onoroh Francis, Chukuneke Jeremiah Lekwuwa, Itoje Harrison John International Journal of Engineering and Innovative Technology (IJEIT) Volume 2
- [2] "Design and Development of Thermoelectric Refrigerator ", Mayank Awasthi International journal of mechanical engineering and robotics.
- [3] "A Review on use of Peltier Effects ", Ajitkumar Nikam Dr.Jitendra hole Mechanical Engineering Department, Rajashri Shahu college of engineering Pune.

[4] Critoph, R.E., Refrigeration in developing countries - the renewable options, proc.1st World Renewable Energy Congress, Reading, UK, 1990.

[5] WHO report EPI/ CCIS/85.4, 'Solar powered refrigerator for vaccine storage and icepack freezing, Status summary June 1986', 1986.

[6] Vivek Gandhewar, Priti Bhadake, Mukesh MAngatani, Fabrication of solar operated heating and cooling using thermo-electric module, IJETT journal -volume 4 issue 4 - April 13

[7] Umesh Sangle, Priyanka Jawhar, G.R.Siloskar, Thermoelectric refrigeration using solar energy for domestic appliance, IJRAT journal -volume 3 no 1-Jan 15

[8] Manoj Rawat, Prasanta Sen, Himandri Chattopadhyay, Developmental and Experimental Study of Solar Powered Thermoelectric Refrigeration System, IJERA journal - volume 3 -issue 4 -Aug 13

[9] T. Paing, J. Shin, R. Zane, and Z. Popovic, "Resistor emulation approach to low-power RF energy harvesting," IEEE Trans. Power Electron., vol. 23, no. 3, pp. 1494-1501, May 2008

[10] J.Karki.(2000,Oct.).Solar Panel Design and solar panel parametrs [Online]. Available: <http://www.science.unitn.it/~bassi/Signal/TInotes/sloa049.pdf>

[11] C. K. Lee, P. K. Chan, and S. W. Or, "Loosely power flow control scheme for piezoelectric energy harvesting," IEEE Electron. Lett., vol. 46, no. 25, pp. 1689-1691, Dec. 2010.

[12] MayankAwasthi and K V Mali, "Design and development of thermoelectric refrigerator", Int. J. Mech. Eng. & Rob. Res. 2012, Vol. 1, No. 3, October 2012, ISSN 2278 - 0149.

[13] Dai YJ, Wang RZ, Ni L;. Experimental investigation and analysis on a thermoelectric refrigerator driven by solar cells. Sol Energy Mater Sol Cells 2003