

SMART SENSOR INTERFACE FOR INDUSTRIAL ENVIRONMENT MONITORING SYSTEM IN IoT

ASHWINI B. BOBADE

Department of E&TC, Deogiri Institute of Engineering and Management Studies, Aurangabad, India

PROF. A. R. WADHEKAR

Department of E&TC, Deogiri Institute of Engineering and Management Studies, Aurangabad, India

ABSTRACT:

The system of wireless sensor network for an industrial environment monitoring is composed of a number of sensors with a networking capability this can be deployed for real time monitoring purpose. Internet of Things (IoT) system allows object to be sensed remotely across existing network infrastructure. The industrial environment determination involved some parameters such as the Temperature, Gas and Light is measured in the real time by the sensors that send the data to the base station or monitoring room. This paper proposes how such monitoring system can be setup emphasizing on the aspects of low cost and easy maintenance and handling. The benefit of wireless system for monitoring purpose will not only reduce the overall monitoring system cost but will also provide flexibility in term of distance or location. Transfer of sensor data from transmitter section to receiver section through zigbee technology. The project is combined with the advanced ARM programmable technology and the advanced sensor specification. In this system device control is also possible through automatically by giving limit to sensor output.

KEYWORDS: ARM7, Internet of Things (IoT), Sensors.

I. INTRODUCTION

Now a recent year's system is automated in order to face new different challenges. In the fast growing days of technology in industrial environment, many sensors plays very important role to minimize human interference in system. It reduces human efforts. Internet of Things allows object to be sensed and remotely across existing network infrastructure. Computer communication systems and especially the internet are playing an important role in the daily life. In this system an automated smart sensor system has designed around a microcontroller. According to this project, sensor network is used to monitor industrial environment continuously.

The transmitter part consists of various sensors, microcontroller interface with XBee and the receiver section consist of a laptop or computer interfaced with XBee. The monitoring tasks in various industries are of crucial importance with respect to safety and efficient

operation. This system is use to reduce electricity wastage in the various industry. This project develops to reduce wiring constraints and also control devices automatically by giving certain limit to sensor. The system can collect sensor data intelligently. The proposed system is requiring less cost and easy customization. Internet of Things is the network of physical objects like devices embedded with software, sensor and network connectivity that enables this objects to collect and exchange data. The objective of this project is to develop a system, which demonstrates intelligent monitoring and controlling system. The main objective of this project is to design an efficient and robust system for monitoring environment in industry and to minimize the effect of these parameters without affecting the natural environment.

II. RELATED WORK:

Qingping Chi et al. proposed a method to develop a reconfigurable smart sensor interface for industrial wireless sensor network in Internet of Things (IoT) environment, which is complex programmable logic device (CPLD), is adopted as the core controller [1]. System to measure and monitor the concentration levels of different greenhouse gases in the industry important to develop. This system measures different gases such as Methane, Carbon Dioxide and Carbon Monoxide gases. GSM module used to transmit information sent to the respective corporations. It uses system to interconnect with the users directly using SMS to know the conditions at the desired sites [2]. Security plays a major role in today's world, good safety systems are to be implemented in places of education and another important area. That work modifies the existing safety model installed in industries and this system also be used in homes and offices. The main aim of the system is developing microcontroller based toxic gas detecting and alerting system in the given fields [6]. Sensors are interfaced with the microcontroller ATmega328p. The measured values are sent from environment monitoring station to the receiver station using zigbee [3]. The project deals with the design and development of Wireless Sensor Node for Wireless Sensor Network for monitoring the industrial parameters [4]. The smart environment monitoring station consists of core controller based measuring units which collect the value of

the temperature, relative humidity and sunlight. These units send their data wirelessly to a station [7]. The wireless connection is implemented to get data from the different sensors, in addition to reduce complexity of the system. By using Bluetooth technology system sends the sensors data to authorized person [5].

III. PROPOSED SYSTEM:

The proposed project is divided into two sections. Fig.1 shows block diagram of transmitter section. In this section LPC2148 controller has used. In which temperature sensor, carbon monoxide (CO) gas sensor and light detecting sensor are used. These three sensors are used for monitoring industrial environment. Power supply given to ARM7 kit. Two devices connected to microcontroller. In this project, 12V DC fan consider as first device and light emitting diode (LED) consider as second device. LCD display use to show sensors output at transmitter section. Sensors transmit data from one place to another through XBee module. Two XBee modules are used in this project. One XBee is at transmitter section and another is at receiver section. Fig. 2 shows transmitter section in which receiver XBee send data to computer, by using internet data display on web page for monitoring Environment.

In this work the micro-controller is playing a major role. Microcontroller is responsible for collecting environmental information (such as temperature, LDR, CO, etc.). LPC2148 has flash memory of 512KB and Static-RAM of 40KB. It has two ports. Onboard regulator generates 3.3V supply. XBee is an established set of specifications for wireless personal area networking. It consumes very low power and provides secure networking. Two XBee modules are used for the transmitter and the receiver.

First sensor national Semiconductor’s LM35 IC has been used for sensing the temperature, whose output voltage is linearly proportional to the degree Celsius temperature. Second sensor is Light Dependent Resistor (LDR) also known as photoconductor or photocell, is a device which has a resistance which varies according to the amount of light falling on its surface. The Light Dependent Resistor (LDR) is made using the semiconductor Cadmium Sulphide (CdS). The light falling on the brown zigzag lines on the sensor causes the resistance of the device to fall. This is known as a negative co-efficient. Third sensor is a Carbon Monoxide (CO) sensor, suitable for sensing CO concentrations in the air. This sensor has a high sensitivity and fast response time.

IV. RESULT:

Sensors continuously monitor the conditions of equipment’s and give its responses to LPC2148 controller and this controller sends the information to computer. The proposed system was fully designed and tested to demonstrate its feasibility and effectiveness. LCD display section is basically meant to show up the status of the project. In this system makes use of Liquid Crystal Display to display or prompt for necessary information

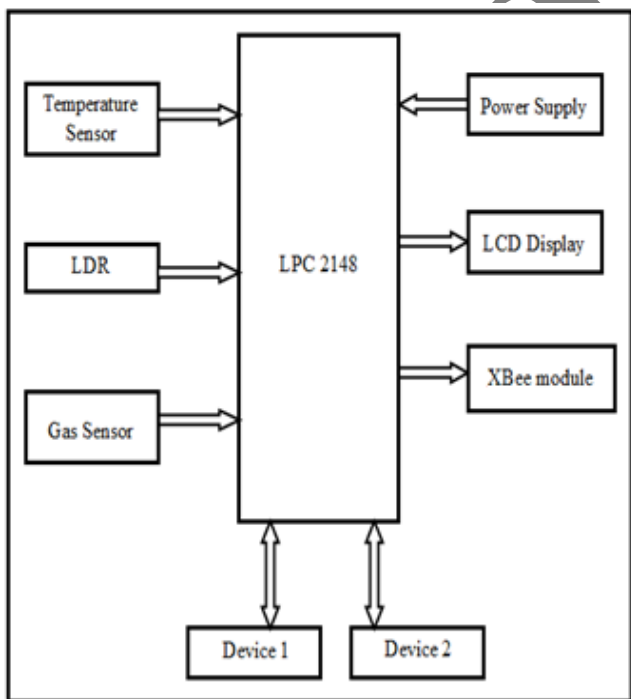

Fig. 1 Block diagram of Transmitter section

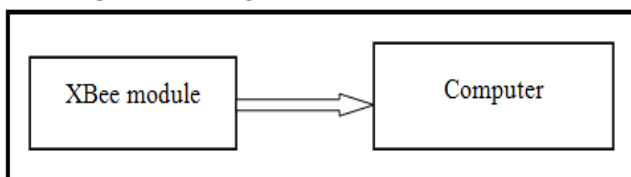

Fig. 2 Block diagram of Receiver section

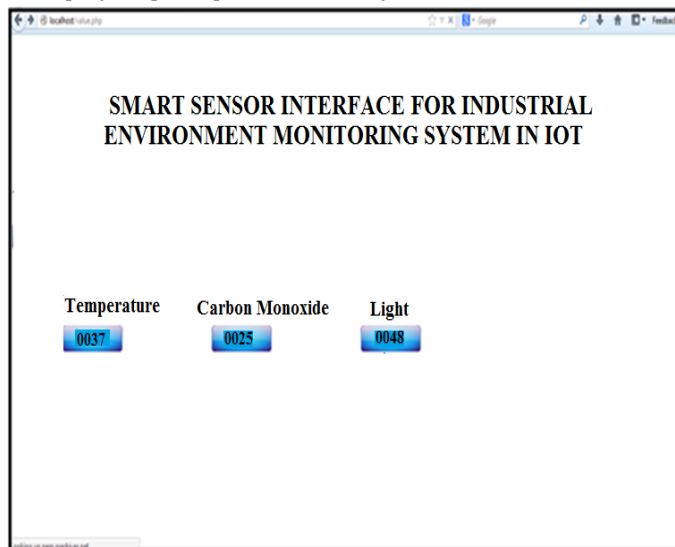

Fig. 3 Data display

The screenshots of the developed system has been presented Fig. 3. In which we can monitor environment through output value of three sensors shown in figure.

V. CONCLUSION

Nowadays we need everything computerized. In industries to reduce manual work we have implemented Internet of Things (IoT) in the industry to monitor environment. The application of ARM greatly simplifies the design of different peripheral circuit, and makes the whole system more flexible and extensible. It is a simple and cost-effective control implementation system. The accuracy indicates how closely the sensor can measure the actual or real world parameter value. This system is time saving, portable, affordable, consumes less power and can be made easily available so that anyone can use this system whenever and wherever.

REFERENCES:

- [1] Qingping Chi, Hairong Yan, Chuan Zhang, Zhibo Pang, and Li Da Xu, "A Reconfigurable Smart Sensor Interface for Industrial WSN in IoT Environment", Vol. 10, NO. 2, MAY 2014, IEEE Transactions on Industrial Informatics.
- [2] Santosh. B. Panjagal, Mr. C. Chandrashekhar, "Design and Implementation of Remote Environment monitoring System for Industry and Landfill Sites using ARM7 PROCESSOR", International Journal of Engineering Sciences & Research Technology, August, 2014.
- [3] Bharani M., Elango S., Ramesh S.M., and Preetilatha R., "An Embedded System Based Monitoring System For Industries By interfacing Sensors With ATmega Microcontroller" International Journal of Advanced Research in Electronics and Communication Engineering (IJARECE) Volume 3, Issue 11, November 2014, pp. 1472-1474.
- [4] P.V. Mane-Deshmukh, B.P. Ladgaonkar, S. C. Pathan, S. S. Shaikh, "Microcontroller Pic 18f4550 Based Wireless Sensor Node to Monitor Industrial Environmental Parameters", Volume 3, Issue 10, October 2013.
- [5] K. Thejus Deep Prathihastha¹, G. Ramanjaneya Reddy, "a reconfigurable sensor network for industrial monitoring", Journal Research in Electrical Electronics and Communication(JRECS) Issue 6.Vol.2.
- [6] V.Ramya, B. Palaniappan, "Embedded system for Hazardous Gas detection and Alerting", International Journal of Distributed and Parallel Systems (IJDPS) Vol.3, No.3, May 2012.
- [7] M. Haefke, S. C. Mukhopadhyay and H. Ewald, "A Zigbee Based Smart Sensing Platform for Monitoring Environmental Parameters", 2011 IEEE.
- [8] Harish Ramamurthy, B.S. Prabhu And Rajit Gadhireless, April - 2007, "Wireless Industrial Monitoring And Control Using A Smart Sensor Platform".