

# INTELLIGENT NIGHT VISION SYSTEM FOR AUTOMOBILE BASED ON COMPUTER VISION

ROHINI VILAS KAMBLE

M.E. (Electronics) Student,

Tatyasaheb Kore Institute of Engineering and Technology, Warananagar

PROF. S.S.PATIL

Professor,

Tatyasaheb Kore Institute of Engineering and Technology, Warananagar

## ABSTRACT:

In today's world where we are witnessing second generation of automotive night vision systems uses near cameras in combination with pedestrian detection systems. This system is intended towards the increasing drivers' visibility in the night by focusing attention of driver by showing all pedestrian on a display provided in the car. This helps in analyzing the imminent situation by providing and more and accurate information of all objects or persons in the path.

Thus, the next generation of night vision systems needs to integrate an additional warning component which signals to the driver only the relevant objects, that is, all objects on the road or near the road. Such systems needs to detect objects more reliably and sooner and has to provide information about the object's position. Rain, fog and wet road way surfaces dramatically alter visibility of driver. It reduces the visibility of drivers' water on pavement increases forward reflection while reducing backward reflection, resulting in glare to oncoming vehicles. Camera detects the oncoming vehicle and sensor automatically adjust headlight glare.

**KEYWORDS:** Intelligent night vision, Rain sensor, Pedestrian security, Automobile safety etc.

## INTRODUCTION:

Safety ratings are given by government authorities in between 1 to 5 stars. These star ratings indicate the level of safety provided for automobile and pedestrians in the event of a crash, as well as its ability through technology to avoid a crash. Safety of vehicles is one of the top priorities in car design and development nowadays. Few safety systems have been developed in research to produce vehicles that will perform at the highest level of safety and also ensures comfortable driving under various conditions. Driven on the highway at night, it is required that light beam should be of high density and should illuminate the road at a distance sufficiently ahead.

Dangerous traffic accident is easy to happen when vehicles move on curve roads at night. The main reason is conventional front light does not provide sufficient and reasonable illumination for nighttime visibility to be adapted to curves. On that situation, Adaptive Front light system (AFS) of vehicles is simulated. The percentage of occurring major accident at night is 1.5 times that of at day time, out of which 60 percent accidents occur on curve roads of bad illumination conditions. The most important reason is that the area of irradiation of the front light is not at the proper position which conduce low visibility and leads to accident. Because of this, a new technology of enhancing vehicle driving safety appears

which is known as Adaptive Front light system (AFS).

AFS is front lighting system that can change the light pattern and illumination area according to the vehicle's state such as the turning angle of road, and distance from incoming vehicle or object to light the road ahead effectively so as to reduce accidents at night.

According to traffic accident data, the highest traffic accident occurs at curve road during the night time. Night time driving with existing conventional headlamps is particularly unsafe because it does not provide illumination in the right direction on curve roads. Due to this constrain, a need to understand an alternative technology solution to improve visibility for driver at night time during curve road. The proposed new adaptive front lighting system (AFS) which is based on camera is better than traditional front lighting system. AFS used to detect information about corner in advance with the help of camera and ultrasonic distance sensor. This proposes a flexible front light for automobiles to illuminate road ahead in the night at corner through this may help in avoiding "blind spot" caused by the fixed lighting area when coming into the corner, and improve driving safety.

#### **IMPLEMENTED SYSTEM:**

According to traffic accident data, the highest traffic accident occurs at curve road during the night time. Night time driving with existing conventional headlamps is particularly unsafe because it does not provide illumination in the right direction on curve roads. At the same time high intensity beam focused directly on line of sight of opposite driver increases chances of accidents. Due to this constrain this system proposes an alternative technology solution to improve visibility for driver at night time during curve road and to reduce glare of the front lights. The system mainly consisting 3

systems which are mentioned below and better than traditional front lighting system:

1. Canny Front lighted Autofocus [1]
2. Electronic Handler for lamps like a pair of eyeballs [2-4]
3. Sensor driven Side windows and wiper [5]

#### **1. CANNY FRONT LIGHTED AUTOFOCUS:**

On the basis of statistics of accident data, most accident are occur at the night time so that it is great importance to use available technology to contribute to road safety by improving the visual condition provided by vehicle headlight. The focus of proposed method is to reduce the reaction time of the driver by improving visibility and to increase road safety without compromising on driving comfort.

Headlights are having two beams called low and high are used which have different purpose during night ride. Position of low beam is fixed to have proper visibility during night while the glare of high beam changes when oncoming vehicle detected. Detection of oncoming vehicle will be done with the help of sensor unit fixed at the center of the vehicle that consequently reduces glare of the headlights.

Night vision system focuses on detecting, illuminating and recognizing road signs at night. Camera is adopted to tackle the problem of low visibility at night. Computer vision techniques, such as image enhancement, object detection. Camera will adaptively change the direction if vehicle is turning. The camera automatically adjust angle so that it always captures front view.

#### **2. ELECTRONIC HANDLER FOR LAMPS LIKE A PAIR OF EYEBALLS:**

Electronic Handler System is a system where the headlamp orientation system rotates

the right and left beam headlights and keeps the beam as parallel to the curved path as possible as to provide better night time visibility with the change in steering angle. Steering system is mainly composed of steering wheel rotation sensors, electronic control unit (ECU), motor drive circuit, motors and so on. The basic idea behind adaptive lighting is to turn and aim the headlights like a pair of eyeballs so the light is projected where the driver really needs it. Inputs from the steering are used to steer the headlights from side to side as the vehicle turns.

Adaptive front lighting system (AFS) helps improve driver's visibility at night time. AFS (adaptive front-lighting system) is a front-lighting system that can change the light pattern and illumination area according to the vehicle's state such as the turning angle of road, and distance from incoming vehicle or object to light the road ahead effectively so as to reduce accidents at night.

The current static headlamp provides illumination in tangent direction of the headlamp without any consideration towards the turning angle of road and the distance between incoming vehicle and subject vehicle. Standard headlights shine straight ahead, no matter in which direction the car is moving. When going around curves, they illuminate the side of the road more than the road itself.

Figure shows, when going around curve car 1 illuminate side of road more than road itself. Car 1 uses the traditional illumination system in case of car 2 it uses adaptive front lighting system which illuminates road area more than side area. AFS therefore improving driver's visibility during night driving by automatically turning the headlamp in direction of travel according to curve road and distance between two vehicles.

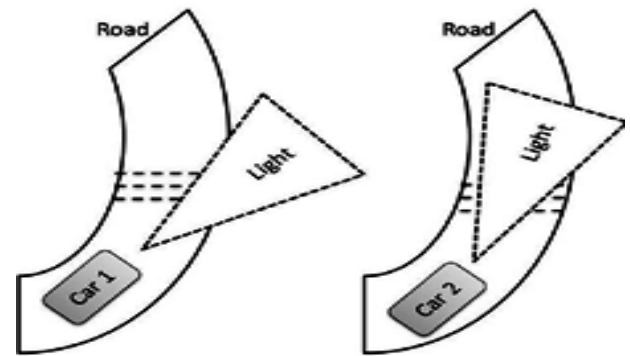

Fig.1. systematic view of the problem definition

### 1. SENSOR DRIVEN SIDE WINDOWS AND WIPER:

Driver feels discomfort while driving in rainy and snowy conditions in addition to that driver has to operate wipers manually. This system comprises of existing wiper system with sensor and controller unit. As soon as raindrop falls on sensor board control unit triggers wiper system. This technology also proposes automatic operating of side windows while driving in rainy conditions.

### BLOCK DIAGRAM:

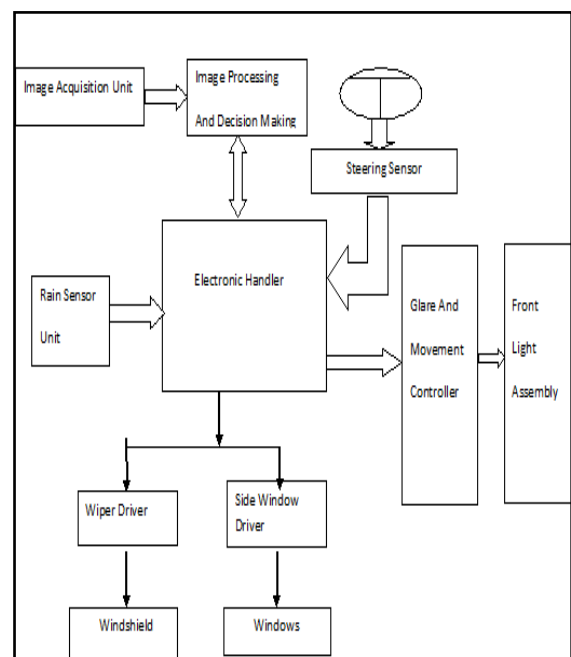

Fig.2. block diagram of the implemented system

Rain sensor unit, Electronic system, Steering system, Image acquisition unit, Image processor unit. Firstly this system considering the above units. The blocks work as per the system. Here we use image processing unit for the purpose of capturing images. For this purpose camera is used. The type of camera is USB. The detection of oncoming vehicles done with the help of camera.

**SOFTWARE DEVELOPMENT:**

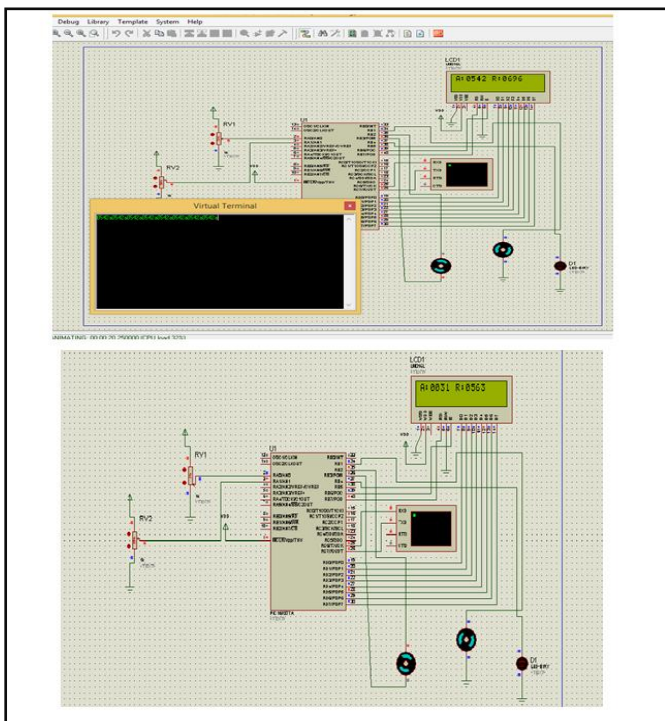

FIG. 4. Developed software images for validation purpose

**DEVELOPED SYSTEM MODEL:**



Fig.4. Images of developed hardware

**FLOW CHART FOR ISR:**

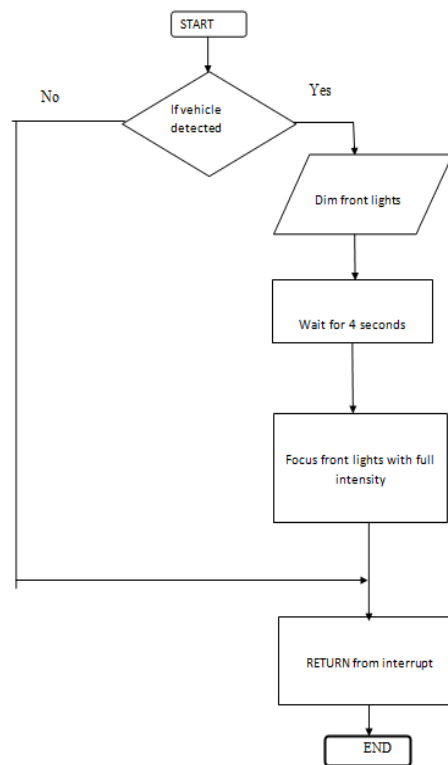

FIG. 5. Flow chart of ISR (1)

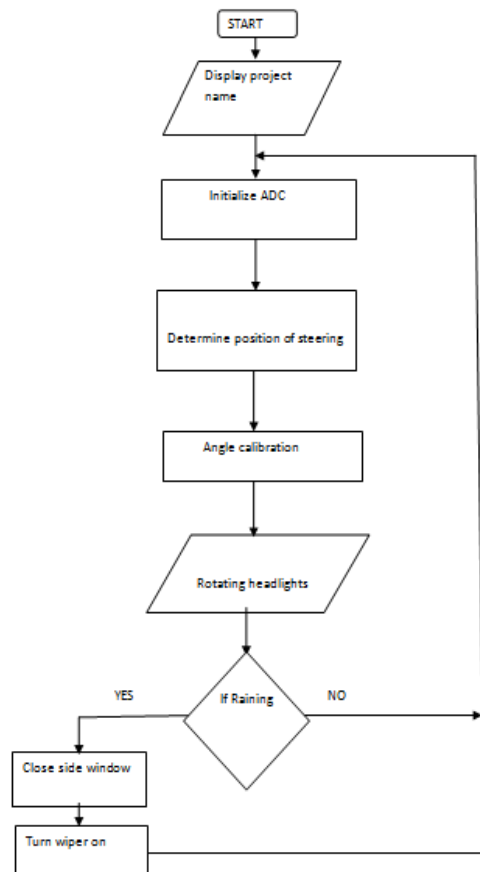

Fig. 6. Flow chart of ISR (2)

## CONCLUSION:

The developed system serves as a reliable and efficient system for efficient driving at sharp turns during night. The system is inexpensive, simple and dependable assembly. This system provides the ability to illuminate the road at sharp turns or corners continuously corresponding to the angular rotation of sensor which is attached to the steering. An advantage of the developed headlight system is in its high adaptability as it can be easily configured to fit on the bumper in variety of vehicle designs. Adaptive headlight system thus can be used as accessory in all running vehicles for proper illumination of road according the driving situation. This ensures higher degree of active safety in vehicles and assistance to driver. The adaptive headlight system is an optimal and cost effective solution to prevent frequent accidents in the nights. The designed system provides degree wise rotations of the headlamps on both side based on the controlled input given to the servo motor attached to the lamps in addition to this feature , Detection of oncoming vehicle is done with the help of sensor unit fixed at the center of the vehicle that consequently reduces glare of the headlights and automatic operating of side windows and wiper while driving in rainy conditions.

## REFERENCES

- 1) Tsz-Ho Yu, Yiu-Sang Moon, Jiansheng Chen,Hung-Kwan Fung,Hoi-Fung Ko and Ran Wang, "An Intelligent night vision system for automobiles" MVA 2009 IAPR Conference on Machine Vision Application, May 20-22,2009,Yokohama,JAPAN
- 2) Meftah Hrairi and Anwar B. Abu Bakar, "Development of an Adaptive Headlamp Systems" IEEE Transaction on Computer and Communication Engineering (ICCCCE2010), 11-13 May 2010, Kuala Lumpur, Malaysia
- 3) Prajka vikas Adhav ,Prof. S. A. Shaikh, "Adaptive front lighting system using CCD" IOSR Journal of Electronics and communication Engineering(IOSR-JECE)e-ISSN:2278-2834,p-ISSN:2278-8735.Volume 9,Issue 5,Ver.III(Sep-Oct. 2014),PP 20-25 www.iosrjournals.org
- 4) Prateek Khurana ,Rajat Arora,Manoj Kr-Khurana, "Implementation of electronic stability control and Adaptive front lighting system for automobiles" 978-1-4799-5912-`-9/14/\$31.00 2014 IEEE
- 5) Hideiri Kajioka I Keiji Fujimura Yasuhiro Fujita, "Automatic wiper control using optical rain sensor" UDC 621.316.7:535.3:629.113 FUJITSU TEN tech. J. No. 2(1989)