

GRID INTEGRATION ANALYSIS FOR COGENERATION AND CAPTIVE PLANT IN SUGAR INDUSTRY: A CASE STUDY OF INDUSHANKAR SUGAR INDUSTRY PVT. LTD., SARLAHI, NEPAL

AJAY KUMAR JHA

Department of Mechanical Engineering, Pulchowk Campus, Institute of Engineering, Tribhuvan University, Nepal
Corresponding author: akjha@ioe.edu.np (A. K. Jha)

SANJEEV RAY

Department of Mechanical Engineering, Pulchowk Campus, Institute of Engineering, Tribhuvan University, Nepal

ABSTRACT:

The electricity sector in Nepal is currently facing the formidable challenges of an insufficient installed capacity, a sub-optimal infrastructure, circular debt and revenue shortage. All of the problems hamper socioeconomic activities. The demand of energy has been consistently increasing annually and the peak demand growth rate of around 10% per year requires addition of generation as well. Nepal, today, experiences a peak power shortage of 12% and an energy shortage of about 8%. To fulfill the gap of demand and supply, integration of industrial cogeneration and captive plant play significant roles. Numerous countries across the globe are consuming bagasse to generate electricity, but regrettably in our country, this valued renewable resource has mostly been thrown away as a mere trash. Analysis of exportable power from sugar industries is an important aspect of the disclosure on grid integration of captive cogeneration plant and resulting environmental impact. This study aimed at investigating exportable power from Indushankar Sugar Industry Pvt Ltd. and analyze the impact of surplus power fed on distribution grid. The GHGs emission is also estimated for bagasse-based cogeneration. The study shows Indushankar Sugar Industry can export upto 7.61 and 5.4 MW during crushing and non-crushing seasons with addition of backpressure condensing turbine in existing cogeneration facility. The simulation study shows losses on feeder lines, busses and transformer as well as percentage voltage drop on the network decreases with the increase in power export. The terminal voltage at different load point also get improved. The short circuit analysis shows the fault level increases with the addition of generating units on distribution grid. The total GHG emission ranges from 1010.88 - 3489.11 tons CO₂eq, against the power generation of 15.55-53.68 GWh, which is expected to avoid the emission of 3250.08 - 38135.99 tons CO₂eq, if the power exported from sugar industry replace the

power generated from diesel plant in the industrial area or NEA's diesel plant.

KEY-WORDS: Sugar industry; Captive Plant; Grid Integration; Environmental Impact.

1. INTRODUCTION:

Nepal is facing increasing power shortage from the last decades. Present installed capacity of Integrated Nepal Power System (INPS) is around 800 MW while the peak demand is of the order of 1400 MW [1]. Even after imports of around 150 MW at different location from India, there is a shortage of 450 MW. The total energy import from India was 1,758.41 GWh which constitute 23% of total energy requirement in 2015/16 [2]. This scenario has raised serious concerns and thus, the Government of Nepal (GoN) has brought various remedial measures and is offering incentives for private investment to generate electricity to bridge electricity supply and demand gap [3]. The government has lately brought a strategy to promote and improve its share of renewable in the energy basket as well for matching the demand and supply of energy [3]. In this scenario, with the increasing demand for rational energy generation, the application of captive and cogeneration power plant in Nepalese sugar industries plants has gained interest. These then need to be integrated with the national/regional power grid. It is therefore of interest to analyze how much energy from sugar industries in exportable to national or regional grid for sustainable energy solution.

During lean session, the shortage of power becomes more severe [4]. To cope with this situation, electricity authorities are imposing load shedding and power cuts. At present the cost involved for adding new generation capacity is about 1.5-2 million USD per MW [5]. Besides this, the cost of transmission and distribution comes to about 1 million USD per Km. Moreover, Nepalese power sector has power generation mainly from ROR type hydropower plants, which are snow fed, and get dry during the

months of dry season. The cane-crushing season is December to March, which coincides with the season of peak electricity demand and minimum hydel power supply. The export of surplus electricity from bagasse cogeneration plant would therefore, play a significant and vital complementary role in reducing impact of energy shortage in the dry months.

The sugar industry has the potential to support Government of Nepal in overcoming current energy challenges. The production of electrical energy from sugarcane fibre is assuming great importance. This is because of its energy security implications which are a result of its renewable nature and also the economic benefits it offers to the sugar industry. Currently the sugar industries have backpressure steam turbines which produces low pressure steam and electricity for self-use. The improvements in energy and process efficiency in the sugar mills can make the mills energy self-sufficient and make them capable of exporting excess electricity to the national grid [1]. It is imperative for the sugar industry to become more energy efficient for it to improve its profitability and contribution to the government's quest for energy security. Cogeneration provides a wide range of technologies for application in various domains of economic activities. The overall efficiency of energy use in cogeneration mode can be up to 85 percent and above in some cases [2].

The paper attempts to assess the potential electricity generation from sugar industries considering sugarcane wastes, namely, bagasse, press mud and also others like fibre residue and leftovers at the field (Sugarcane trash). It then focuses on estimation of exportable power to the grid. The present work also aims to access the potential impacts of integrating captive and cogeneration plant to the distribution network and resulting environment impact.

2. METHODOLOGY:

It specifically employs the case study approach to explore the power generation and surplus power exported from sugar industries to the nearest distribution substation. The analytical software ETAP (Electrical Transient Analyzer Program) is used to study grid impact whereas environmental impact is done using emission factor of bagasse based electricity generation. Indushankar Sugar Industry Pvt. Ltd is selected for case study and Haripur Substation is selected to analyses the grid impact upon integration of captive and cogeneration plant. This study encompasses three main phases as shown in Figure 1.

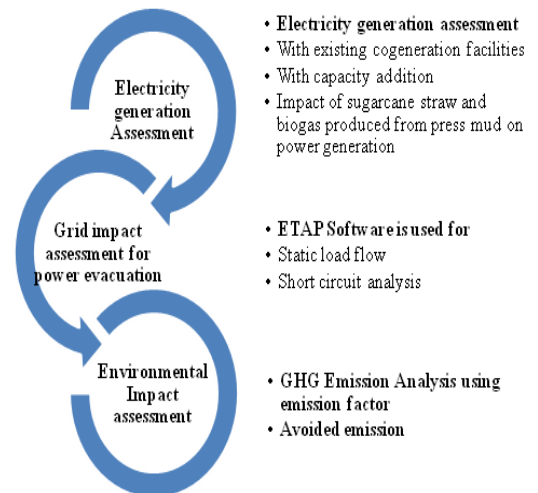

Figure 1: Phases of study to cover the objective

Case Study:

Indushankar Sugar Industry Pvt. Ltd is selected for case study and Haripur Substation is selected to analyses the grid impact upon integration of captive and cogeneration plant. This sugar industry is located at Harion-9, Sarlahi District and is about 320 Km south-east of Kathmandu. The current installed capacity of the plant is 5000 TCD. Sugarcane is sourced from farmers of three districts namely Sarlahi, Mahottari, Rautahat and Dhanusha districts. The factory production season is approximately 117- 150 days mainly during the dry months (December to March). Haripur substation is the nearest grid substation 11 km away from the Indushankar Sugar Industry.

DATA COLLECTION:

Primary:

Some sugar industries were visited, and observations were made on the systems and components. Industries visited include Everest Sugar Industries Pvt. Ltd, Ramnagar, Gaushala, Mahottari, Indushankar Sugar Industry Pvt. Ltd, Harion, Sarlahi and Annapurna Sugar Industries Pvt, Ltd, Dhankaul, Sarlahi. The substation Aaurahi 33/11 kV NEA substation, Gaushala, Haripur 33/11 kV NEA substation and Barathwa 33/11 kV NEA substation, Sarlahi were also visited in order to ascertain the viability of grid interconnection for power evacuation from aforementioned industries respectively. Indushankar Chini Udhyog Pvt. Ltd situated at Harion, Sarlahi, Nepal were selected for detail investigation. During the visits, questions like the production period, sugarcane purchase, bagasse yield, energy consumption, power plant specifications and operating conditions, etc were answered.

SECONDARY:

Secondary data were collected from literature review. A typical level of process steam consumption and electricity consumption collected from literature review are tabulated in Table-2.3.1 and byproducts yield per ton of cane crushed is presented in Table-3.2.-2

Table 0-2: Byproducts yields per ton of cane crushed in sugar industries

Sources	Energy consumption	
	Thermal	Electrical
\cite{deshmukh2013}	400 to 550 kg steam/ton of sugarcane crushed	
\cite{kudarihal2009}	450 kg steam/ton of cane crushed	30 kW/ton of cane crushed
\cite{toolseeram2008}	500 kg of steam consumed/ton of cane processed	22.5 kWh/ton of cane
\cite{velas2013}	450 kg-Steam/tonne cane crushed	104 MJ/tonne cane crushed (i.e. equal to 28.89 kWh per ton)

Table 0-1: Steam and electricity consumption in sugar industries

Byproduct/ Product	Quantity per ton of cane crushed	Sources
Sugarcane trash	0.09-0.14 ton (dry)	\cite{deshmukh2013}, \cite{mane2016}
Bagasse	0.25-0.32 ton	\cite{deshmukh2013}, \cite{toolseeram2008}, \cite{mane2016}
Press Mud	0.03-0.05 ton	\cite{mane2016}, \cite{dot2016}, \cite{pradeep2008}

Bagasse is the fibrous residue obtained after sugarcane juice extraction which contains 45 to 50 % moisture\cite{mane2016},\cite{Agrawal2013},\cite{deshmukh2013}and 1 % ash. Bagasse easily ignites and has free burning quality. Its calorific value is 8022 kJ/kg\cite{mane2016}. For dry bagasse, LHV is 16 MJ/kg and for dry ligneous residue, LHV is 18 MJ/kg. The gross calorific value of bagasse is 19250 kJ/kg at zero moisture and 9950 kJ/kg at 48% moisture. The net calorific value of bagasse is 8000 kJ/kg at 48% moisture\cite{Chauhan2011},\cite{toolseeram2008}.

Filter mud generated during the raw sugar production process, consists of approximately 70% to 80% moisture and possess biogas production potential in a range of 20 to 80 m³ per ton of fresh material\cite{giz14}. Specifically, the press mud or filter cake has potential to produce 0.241 L/g biogas. The calorific value of the biogas varies, ranging from 22.5 to 25 MJ/m³ assuming methane with about 35,800 kJ/m³\cite{kar09}.

GHG emissions per unit bagasse electricity range from 0.0633 kg CO₂eq/kWh to 0.0881 kg CO₂eq/kWh, which is about 4-5 fold lower than 0.3528 kg CO₂eq/kWh for coal electricity. The emission factor for electricity

generation from diesel power plants is 0.98 kgCO₂eq/kWh in Nepal, which is the factor used to calculate avoided emissions in case surplus electricity is produced and sold in the industrial corridor\cite{khat11}.

COGENERATION SYSTEMS:

Four cases for cogeneration were chosen for the analysis of exportable electricity generation from sugar cane factories. The results refer to Indushankar Sugar Industry. Thermal and electrical energy requirements of the process must be supplied by this system and surplus of electricity generated is considered available for sale to the grid. The direct drive steam turbines commonly used for juice extraction system. Table 2 shows the general parameters adopted for all the cases proposed in this study.

Table 0-1: Assumptions for cogeneration analysis

Assumptions	Units	Value
Steam Consumption	kg/ton of cane	450
Electricity Consumption	kWh/ton of cane crush	25
Bagasse % on cane	-	30%
Water % on bagasse (W)	-	50%
Sucrose % in bagasse (S)	-	2.30%
NCV of Bagasse(4250-1200*S-4850*W)	kCal/kg	
Press mud production	Ton/ton of cane	0.03
Recoverable sugarcane trash	Kg/ton	125
Total trash available as a fuel for cogeneration	%	50% of recoverable trash
NCV of Trash	kCal/kg	2390
Production Days (Crushing Season)	days	120
Boiler Thermal Efficiency	-	85%
Steam Turbines Efficiency	-	25%
Electric Generator Efficiency	-	96%
Plant Load Factor for generator (PLF)	-	90%
Biogas produced from press mud	m ³ /ton	241
Electricity generating efficiency of biogas plant	-	30%

Case I: The first case analyzed is a steam cycle with back-pressure steam turbine. In this case the sugar process determines the quantity of steam that can be produced by the boiler, once there is not a condensation system. This kind of cogeneration system is the most common in Nepalese sugar industries and can operate just during the crush season when the factory is in operation and the steam demand exists. The mill has

currently four boiler (2x18TPH, 32 TPH & 60 TPH) and two turbine generator sets each of 3 MW capacity.

Case II: In this case electricity generation assessment is done with Case I and one 3 MW additional back pressure condensing turbine in existing cogeneration facility. The addition of BPC turbine is to consume the surplus bagasse that is estimated to be accumulated in case I for electricity generation. In this case the condenser offers more operation options and higher flexibility, being possible to operate all around the year, in crushing and non-crushing season.

Case III: In this case electricity generation assessment is done with Case I and two 3 MW additional back pressure condensing turbine in existing cogeneration facility. In this study surplus bagasse and cane trash is considered for electricity generation. In this case the condenser offers more operation options and higher flexibility, being possible to operate all around the year, in crushing and non-crushing season.

Case IV: In this case electricity generation assessment is done with Case III and one biogas plant. Making use of press-mud for the production of biogas is a better option. The biogas obtained is used for steam/electricity generation.

SIMULATION MODEL FOR GRID IMPACT:

The model developed containing Haripur substation distribution network, the utility company distribution and proposed transmission systems with step-up transformer for grid impact study is shown in Figure 4.3-1. The simulation study is done with following assumptions.

- The power generation from each generators is 90%.
- The conductor used for 11 kV and 33 kV are DOG conductor.
- The Constant KVA and constant Impedance (Motor and Static) load at Indushankarchiniudhyog are 90% and 10% respectively.
- The Constant KVA and constant Impedance (Motor and Static) load at consumer point are 80% and 20% respectively.
- Chapur substation 33 kV bus is considered as slack bus.

The grid integration study is done with six cases. In Case-1, Simulation is done Before connecting captive and cogeneration plant. In Case-2, simulation is done with grid integration of existing cogeneration plant (2*3 MW). In Case-3, case-2 and one additional BPC Turbine (1* 3MW) is considered. In Case-4, case-2 and two additional BPC Turbine (2* 3MW) is considered. In Case-5, case-4 and one

biogas plant (1*1 MW) is considered and in Case-6, case-5 with three captive diesel generator (0.29 MW + 0.34 MW + 0.106 MW) is considered.

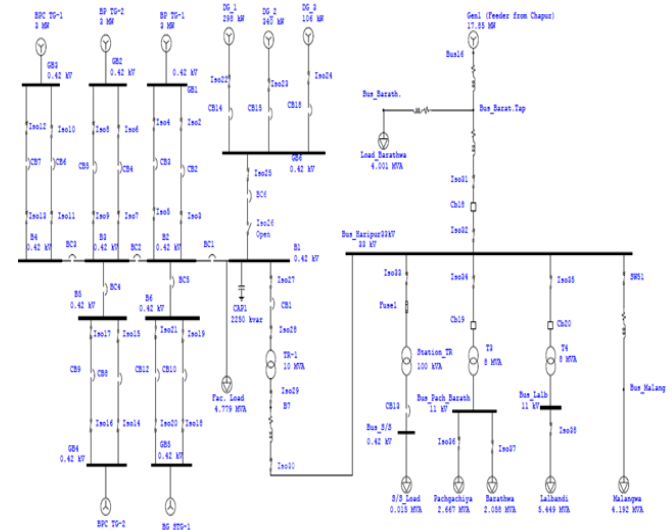

Figure 4.3-1: Simulation Model

3. RESULTS AND DISCUSSION:

Total Electricity Generation and Exportable Power:

The current total installed capacity for the Indushankar Sugar Industry Pvt. Ltd cogeneration plant is 6 MW, however the maximum available capacity has been assumed to be 5.4 MW for crushing season based on the assumption that the generators will be operated on 80% of its maximum capacity and no power is available for off-crop season due to back pressure turbine which doesn't support operation during non-crushing season. With certain modification in the existing configuration and adding back pressure condensing turbine in the existing configuration the power can be generated during non-crushing seasons. The summary of exportable power estimated is shown in Table 5.1-1.

Table 5.1-1: Summary of exportable power to grid

S.No.	Electricity generation with	Installed Capacity	Power Plant in operation (days)		Total Power Generation (MW)		Industrial Power Demand (MW)	Exportable Power (MW)		Total Energy Generated (GWh)
			Crushing Season	Non-crushing Season	Crushing Season	Non-crushing Season		Crushing Season	Non-crushing Season	
1	Existing Cogeneration Facility	6	120	0.00	5.4	0	4.17	1.23	0	3.55
2	Additional BPC turbine and surplus bagasse	9	120	179.76	8.1	2.7	4.17	3.93	2.7	22.98
3	Additional BPC turbine, surplus bagasse and sugarcane trash	12	120	152.50	10.8	5.4	4.17	6.63	5.4	38.87
4	Additional BPC turbine, surplus bagasse, sugarcane trash and biogas produced from press mud	13	120	152.50	11.77605	5.4	4.17	7.61	5.4	41.68

Grid Impact Study:

A technical evaluation is performed using ETAP to illustrate the viability of integration of captive cogeneration plant with distribution grid.

6.2.1 Load Flow Analysis:

For load flow analysis the Haripur substation distribution network and the existing electrical network at Indushankar Sugar Industry Pvt. Ltd. together with possible addition of cogeneration plant are mapped and digitised on ETAP software as per the information collected and then simulated for the corresponding average peak load during peak time (6 PM to 11 PM) on each feeder. The total load on the system is equal to total load connected to distribution grid only in case-1 and in other cases the total demand is equal to the total load connected to distribution network as well as total load connected at factory. Chapur substation 33 kV bus is considered as slack bus for load flow analysis. The details of active and reactive power supply and demand under six different cases are shown in Figure 6.2.1-1.

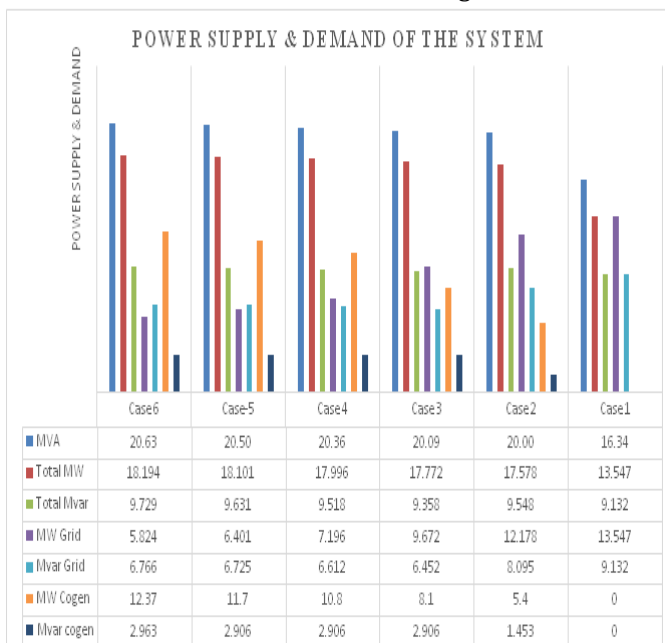

Figure 6.2.1-1: Power supply and demand of overall system

From the above Figure 6.2.1-1, it is seen that in the first case the total power demand of the system that is around 16 MVA is supplied from distribution grid out of which total active power requirement of the system is 13.5 MW and reactive power requirement is 9.13 Mvar. In the rest all cases (cases from 2-6) total power demand during peak hour is around 20 MVA out of which active power is in the range of 17-18 MW and reactive power demand is around 9.5 Mvar. The active and reactive power demand are supplied from both cogeneration plant and the grid.

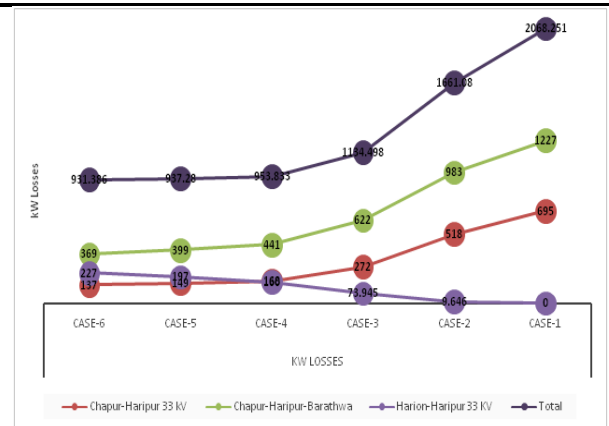

Figure 6.2.1-2: Losses on different feeder

With load flow analysis the total losses on different feeder is analysed under different cases and depicted in Figure 6.2.1-2. The total active power loss of the system is maximum in case-1, which is around 2.1 MW (i.e 13% of total power delivered), and the loss decreases as the power exported from sugar industries increases. The losses on the system is minimum for case-6 and it is around 0.93 KW. This is because the line loss is proportional to square of the current flowing through the line and the length of the feeder.

Likewise the voltage drop in the feeder line and terminal voltage at the different load point is observed and shown in Figure 6.2.1-3 and Figure 6.2.1-4 respectively. From both figure it is seen that the the voltage drop in the feeder lines decreases and terminal voltage at different load points in the feeder section get improved as the surplus power is exported from sugar sugar industries captive cogeneration plant. From figure 6.2.1-3, it is seen that the voltage drop in Chapur-Barathwa and Haripur-Malangwa 33 kV feederline remain same in all cases this is because the power flow through these feeder section remain same.

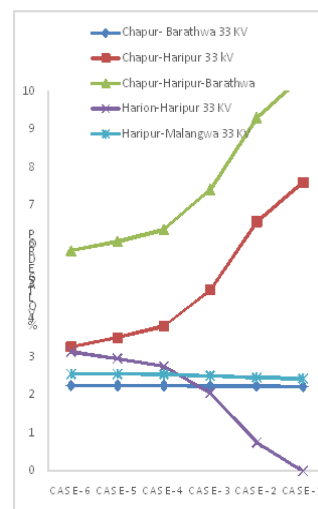

Figure 6.2.1-3: Percentage voltage drop on feeder lines

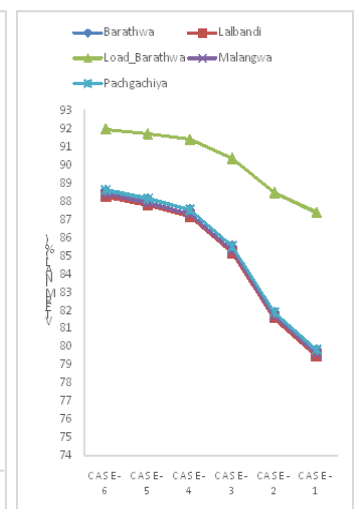

Figure 6.2.1-4: Terminal Voltage at different load point

6.2.2 Short Circuit Analysis

The short circuit analysis is done for all cases considering the three phase bolted fault at 33 kV Haripur Bus and Barathawa-Pachgachiya feeder Bus. From short circuit analysis as presented in Figure 6.2.2-1, it is seen that the fault current at both selected bus Pachgachiya-Barathwa Bus and Haripur 33kV Bus increases after integration of captive plant in Indushankar Sugar Industries Pvt. Ltd on occurrence of fault. The presence of captive cogeneration plant in a network affects the short circuit levels of the network. It increase the fault currents when compared to normal conditions at which no captive plant is installed in the network.

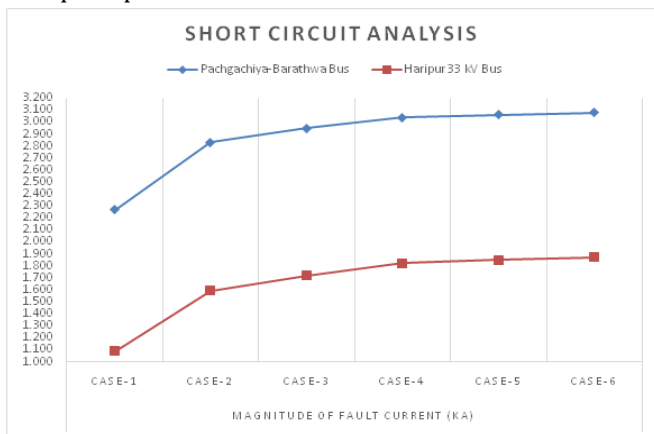

Figure 6.2.2-1: Magnitude of fault current at Pachgachiya-Barathwa Bus and Haripur 33 kV Bus

GHG emissions

This study estimates the GHGs emissions from Indushankar Sugar Industries Pvt. Ltd by using the emission factor of bagasse based electricity generation in sugar industries. The emission factors are used to estimate the GHG emission and the total GHGs emissions from Indushankar Sugar Industry Pvt. Ltd. is 3250 tons CO₂eq from energy generation of 19.1 GWh under existing condition. In this case the amount of power generated from cogeneration steam turbine generator only meet the power demand of sugar mill. The GHGs emission for this factory is mainly depends upon the amount of bagasse and other alternate fuel like sugarcane trash and press mud which are utilized for electricity generation. The use of back pressure condensing turbine generator set allow operation of plant during both crushing and non-crushing season. Thus, in this study the GHGs emission has been done for all cases applied for exportable power estimation. The results are presented in figure 5.3-1. The total GHG emission ranges from 1010.88 - 3489.11 tons CO₂eq, against the power generation of 15.55-53.68 GWh, which is expected to avoid the emission of 3250.08 - 38135.99 tons CO₂ eq, if the power exported from sugar industry replace the power generated from diesel plant in the

industrial area or NEA's diesel plant. The avoided GHG emissions $(=(0.98-0.065)/0.98= 93\%)$ indicates that exporting surplus bagasse electricity from sugar industries, instead of operating NEA's diesel plant to generate electricity avoids the release of a significant amount of GHGs to the atmosphere, thereby contributing towards climate change mitigation.

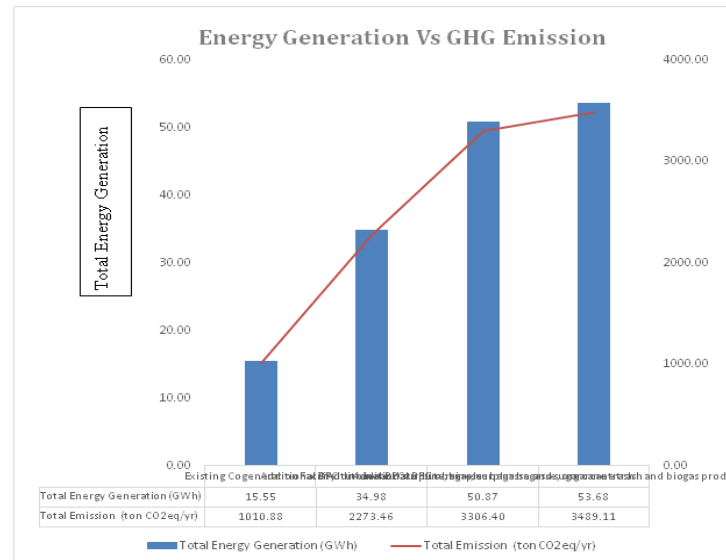

Figure 5.3-1: Energy Generation and GHG Emission

4. CONCLUSION:

The electricity generation assessment with existing cogeneration facility shows 1.23 MW power and 3.55 GWh energy can be supplied to the grid during crushing seasons of around 120 days. After meeting the thermal and electrical demand, 50,693.62 MT bagasse remain surplus which is around 25% of total bagasse available per season. After addition of 3 MW back pressure condensing turbine generator sets in the existing cogeneration facility, 3.93 and 2.7 MW power can be exported to the grid during crushing (120 days) and non-crushing season (180 days) which is equivalent to 22.98 GWh energy per year.

The residue usually left at the harvest field for agricultural purposes when recovered (recoverable quantity of 125 kg trash/tons) and considering 50% of the recoverable straw, total 30,000 MT (20% of total bagasse) is available for boiler operation. To utilize surplus bagasse and cane trash, electricity assessment done with two additional back pressure condensing turbine shows 6.63 and 5.4 MW power can be exported to grid during crushing and non-crushing season of 120 and 152 days respectively which is equivalent to 38.87 GWh energy per year. Another assessment of electricity generation considering biogas produced from press mud shows 1 MW power can be added to the grid.

Demonstration of the grid impact study shows the losses on feeder lines, busses and transformer as well as percentage voltage drop on the network

decreases with the increase in power export from sugar industry. Terminal voltage at different load point also gets improved with increase in power export from sugar industry. The short circuit analysis shows the fault level increases with the addition of generating units. The overarching view from the results is that the outlook for grid interconnected captive and cogeneration plant in future is positive in Nepal.

The total GHG emission ranges from 1010.88 - 3489.11tons CO₂eq, against the power generation of 15.55-53.68 GWh, which is expected to avoid the emission of 3250.08 - 38135.99 tons CO₂eq, if the power exported from sugar industry replace the power generated from diesel plant in the industrial area or NEA's diesel plant.

5. REFERENCES:

- 1) Agrawal, K. M., Barve, B. R. & Khan, S. S., 2011. Biogas From Pressmud. IOSR Journal of Mechanical and Civil Engineering (IOSR-JMCE), pp. 37-41.
- 2) Alam, F. et al., 2016. A review of hydropower projects in Nepal. Melbourne, Australia, ScienceDirect.
- 3) Azevedo, J. M. D. & Galiana, F. D., 2009. The Sugarcane Ethanol Power Industry in Brazil: Obstacles, Success and Perspectives. s.l., s.n.
- 4) BEE, B. o. E. E., 2015. Energy Efficiency in Thermal Utilities, 4th floor, Sewa Bhawan, R.K. Puram, New Delhi-110066: s.n.
- 5) Chronowski, R. A., 1990. Sugar industry of pakistan: Potential for grid power supply, 1400 I Street, N.W., Suite 700, washington, DC. 20005: International Resources Group.
- 6) Damodaran, C., 2015. Energy audit in Sugar Industry- A Passport to Prosperity. [Online] Available at: www.avantgarde-india.com/techpapers/Energy
- 7) Kumar, D. P., 2013. Overview of cogeneration opportunities in nepalese sugar sector, Nepal: GIZ-NEEP.
- 8) Mbohwa, C., 2013. Energy Management in South African Sugar Industries. Proceedings of the World Congress on Engineering, July.
- 9) MoEn, M. o. E., 2012. Implementation Plan for Eradication of Energy Scarcity and Electricity Development Decades, s.l.: Ministry of Energy, MoEn.
- 10) NEA, N. E. A., 2016. A Year in Review Fiscal Year 2015/16.
- 11) Nyonje, E. O., Njogu, P. & Kinyua, R., 2014. Assessment of the potential for utilization of sugarcane derived press mud for biogas generation in South Nyanza sugarcane zones, Kenya. s.l.,

Proceedings of 2014 International Conference on Sustainable Research and Innovation.

- 12) Rebecca, M., 2007. [Online] Available at: www.adb.org/Documents/Events/2002/ADB_ESCAP_Workshop