

## **REVIEW OF REALIZATION OF THREE PHASE TWO STAGE GRID SYSTEM BY USING LLC RESONANT CONVERTER**

Mr. Bhooshan Dileep Darkonde

Designation : Scholar; Organization : SSSIST, City : Sehore, State : Madhya Pradesh , Country : India

Prof. Prabhodh Kumar Khampariya

Designation : Head of the Department; Organization : SSSIST, City : Sehore, State Madhya Pradesh, Country : India

**Abstract—** Module integrated converters (MICs) in single phase have witnessed recent market success because of unique features such as improved energy harvest, improved efficiency of the system, lower installation costs, plug-and play operation, and enhanced flexibility and modularity. A niche market has been grown by the MIC sector to mainstream, especially in the United States. Assuming further expansion of the MIC market, this paper presents the micro inverter concept incorporated in large size photovoltaic (PV) installations such as megawatts (MW)-class solar farms where a three-phase ac connection is employed. A high-efficiency three-phase MIC with two-stage zero voltage switching (ZVS) operation for the grid-tied PV system is proposed which will reduce cost per watt, improve re-liability, and increase scalability of MW-class solar farms through the development of new solar farm system architectures. The first stage mainly considered for a high efficiency full-bridge LLC resonant dc-dc converter which interfaces to the PV panel and produces a dc link voltage. A center point's iteration algorithm developed specifically for LLC resonant topologies is used to track the maximum power point by the PV panel. The second stage is comprised of a three-phase dc-ac inverter circuit which employs a simple soft-switching scheme without adding auxiliary components.

**Keywords-** Center points iteration (CPI), maximum power point tracking (MPPT), module integrated converter (MIC), three phase two stage converter.

### **1. Introduction**

With ever degenerate natural resources and increasing demands for power, the need to seek out viable alter-native sources of renewable energy is not just critical urgent. Due to the fact that solar energy offers extraordinary merits including environmentally neutral, unlimited availability and low cost capable of competing with conventional sources with technology advances and mass production in the coming few years. Over of 25% growth on an average over the last 10 years has been seen by the photovoltaic (PV) industry Other than the PV panel itself [1], the inverter is the most critical device in a PV system both for off-grid or grid-connection applications because the property of the inverter uses to converts dc supply to ac supply and ac supply is converted in dc supply is called as rectifier, this is called as converter. The basic concept of the converter is that to get the required supply. Now-a-days, the PV system

architectures can be categorized into three basic classes with respect to the types of grid-tied inverter: i) central inverter, ii) string or multi string inverter, iii) module integrated converter (MIC) (also called micro inverter) [2][3]. Although the central inverter can be operated at high efficiency with only one dc/ac power conversion stage, this system has some drawbacks:

1) Each PV module may not operate at its maximum power point which results in less energy utilized.

2) Additional losses are take-placed by string diodes and junction box; and

3) Single point of failure and Mismatch of each string or PV panel affects the PV array efficiency greatly. The string inverter is a modified version of the central inverter. It partially overcomes the issues arising in central inverters; however, it still suffers some of the drawbacks of the central inverter. In an effort to maximize the power from each PV panel, a new approach was recently proposed which can be applied to either central or string inverter architectures. A power maximize is attached to each PV panel to utilized maximum power tracking. Although the architecture maximizes power from each PV panel at the cost of additional dc/dc module, it still suffers from such drawbacks like high-voltage hazard, single-point failure, and difficulty in maintenance. The MIC typically used in distributed PV systems is a small grid-tie inverter of 150- 400 W that converts the output of a single PV panel to ac. The MIC ac outputs are connected in parallel and routed to a common ac coupling point. No series or parallel dc connections are made leaving all dc wiring at a relatively low voltage level of a single panel module. The MIC can be further integrated into PV modules to realize a true plug-and-play solar ac PV generation system. Thus, ac PV modules with integrated MIC have significant advantages over traditional PV systems since they allow maximum peak power tracking on each solar panel to maximize energy utilizing, and offer distributed and redundant system architecture. In addition, MIC and ac PV systems greatly simplify system design, eliminate safety hazards, and reduce installation costs .With these advantages; the trend for future PV system has been became by the ac module for development. Although MIC and ac PV modules have witnessed recent market success, MIC still has many technical challenges remaining such as high efficiency, high reliability at module level, low-cost and high-level control issues. To date, research of the MIC has mainly focused on isolated topologies for the following two reasons: 1) from reported literature, most topologies with a few exceptions cannot meet the dual grounding requirement without transformer isolation according

to the UL1741 standard; and 2) using transformer is the best way to boost the low input voltage to high output voltage for ac grid with high efficiency. Since line transformers are bulky and costly, this architecture is not practical for MIC. This paper mainly focuses on the architecture employing a high-frequency transformer. The MIC with its high-frequency transformer can be grouped into three architectures based on the dc-link configurations: dc-link, pseudo-dc-link, and high-frequency ac. Usually the MIC just pumps the power from PV to ac grid with unidirectional power flow. However, with the presence of the power decoupling capacitor, MIC can support the ac grid not only as an ac power source, but as a VAR and possibly a harmonics compensator as well. For the latter two cases, bidirectional power flow is needed between ac grid and the power decoupling capacitor requiring MIC with bidirectional power flow capability. For applications with power levels under several kilowatts, generally the single-phase connections are used.

## **2. Literature Survey**

Resonant converters have been cramped in the last some decades of years to niche applications such as very high voltage applications or high fidelity audio systems while much effort was spent in research by industries and universities because of its attractive features: smooth waveforms, high efficiency and high power density. In recent times the LLC resonant Converter in particular in its half-bridge implementation, has been widely and successfully applied to flat panel TV, 80+ ATX and small form factor PC, where the requirements on efficiency, power density and EMC compliance of their switching mode power supplies (SMPS's) are getting more and more rigid. However future SMPS requirements will have to face one of the few remaining disadvantages of LLC resonant converter topology that is related to the output filter capacitors volume that represents the major limit for such applications. The injection of rectified sine wave currents into the output filter capacitor can be adequately mitigated by the parallel use of multiple modules such as in interleaved buck solutions for voltage regulator modules. This topology has been presented in for two modules operating with 90 degrees phase shift. One of the drawback of this solution is represented by the inherent current unbalance caused by resonant component mismatch that may cause one of the two modules to reduce its output power down to zero, thus requiring mandatory workarounds to overcome the problem Resonant converters are commonly selected for applications which demand for a high power density and a high energy efficiency. By featuring soft-switching, the switching frequency can in general be chosen much higher than the switching frequency of a comparable hard-switching converter. As a consequence, the volume required for the passive components is drastically reduced, enabling high power densities and high power conversion efficiencies. In this paper, a highly efficient battery charger has been designed, for

which is capable of bidirectional charging light electric vehicles (LEVs). The charger will be connected to a dc micro-grid at  $V_{dc} = 450V$  and will feature an output voltage range from 17V to 56V. For limiting the duty-cycle and/or frequency variation, and to provide galvanic separation from the dc-bus, a transformer is needed for this type of application; the LLC resonant converter synchronizes remarkable unidirectional performance. In a bidirectional LLC prototype was built, but no optimized modulation schemes were employed and the converter did not achieve satisfactory power conversion efficiency. In a Symmetric fourth-order resonant converter was built based on an LLC resonant tank, featuring an additional resonant capacitor. However, the proposed CLLC converter operates in boost-mode in both directions and is therefore not very suitable for use as a voltage-regulating converter. the LLC resonant converter has been drawn a lot of attention due to its drawbacks over the conventional series resonant converter and parallel resonant converter, narrow frequency variation over wide load and input variation and Zero Voltage Switching (ZVS) of the switches for entire load range. An analysis and reviews practical design considerations are presented in this paper for the LLC-type resonant converter. It includes designing the transformer and selecting the components. The step-by-step design procedure explained with a design example will help engineers design the LLC resonant converter easily. The effect of resonant component mismatch will also be explored and a suitable star connection solution will be investigated to overcome current derating limits by means of intrinsic balancing. Measurements on a prototype will be included in the paper as validation of assertions and proposals [4].

The Basic requirements of battery chargers with switching regulators are small sized and high efficiency. High switching frequency is necessary to achieve a small size. However, the switching loss will increase as the switching frequency is increased. This condition, in turn, decreases the efficiency. To solve this problem, some kinds of soft-switching techniques need to be used to operate under high switching frequency. One simple solution to a soft-switching converter is loaded resonant converters. By adopting these topologies, either voltage or current is zero during switching transition, which largely reduce the switching loss and also increase the reliability for the battery charger. It eliminates both lowland high frequency current ripple on the battery, thus maximizing battery life without penalizing the volume of the charger [5].

The isolated unidirectional LLC resonant converter is known for its outstanding efficiency and high power density. Little information has however been published about the possibility of transferring power in the reverse direction. This paper presents modulation schemes for making the LLC converter bidirectional. High efficiencies are predicted for both directions of power flow, though, as the behavior of the resonant tank is substantially different in the reverse direction, some of the inherent benefits of the conventional LLC converter are lost [6].

In this paper a topology for multi-phase interleaved LLC resonant converter is presented. The proposed solution, based on three LLC modules with transformer primary windings star connection allows to drastically reduce the output current ripple and consequently to minimize the output filter capacitor size. Differently from other multi-phase solutions, that are greatly susceptible to resonant component mismatch and consequently can be affected by a considerable current imbalance among modules, the proposed topology exhibits an inherent balancing capability. Small-signal analysis is presented and the possibility to turn-off one or two modules (phase shedding) at reduced output current levels is discussed, highlighting the trade-off between converter efficiency and output capacitor current ripple reduction. Measurements on a prototype will be included in the paper as validation of assertions and proposals [7].

### 3. Theory

#### Architecture of Two-Stage Three-Phase Grid-Tie Inverter System

In order to provide galvanic isolation, various isolated converters for high step up applications have been proposed. In general, the topologies with galvanic isolation suitable for this application can be categorized into two groups: single-switch topologies and multi switch topologies. Recently, the LLC resonant topology has become attractive due to its desirable characteristics such as high efficiency and natural zero voltage switching (ZVS)/zero current switching (ZCS) commutation. Therefore, a full-bridge LLC resonant converter is employed in the first stage to achieve high efficiency and track the maximum power point of each PV panel. For the three-phase dc/ac converter in the second stage, a variety of active soft-switching topologies have been proposed in last three decades. Most of them can be divided into three groups: auxiliary resonant commutated pole (ARCP) group, resonant dc-link inverter (RDCLI) group, and resonant ac-link converter (RACLC). The ARCP can be applied broadly for the voltage-source type single-phase or three-phase inverters but it requires a large number of auxiliary components. Compared to the ARCP, the RDCLI has the advantages of fewer auxiliary switches and a simpler circuit. Several soft-switching topologies in were proposed to achieve the minimum number of extra components. However, the driving signals of the auxiliary switches are very sensitive to the noise from the main circuit. Since the RACLC can achieve voltage boosting and electrical isolation at the same time, it is highly preferred for renewable energy power generation. Unfortunately, the control circuit for the RACLC is complex and bidirectional switches are required. In fact, auxiliary components are unavoidable for all of the soft switching topologies mentioned earlier. The proposed soft-switching technique shown in Fig.1 simplifies the inverter topology and reduces the cost since it does not require any auxiliary components.

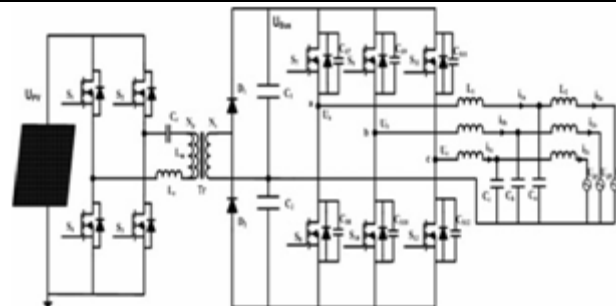

Fig. 1 Two-stage three-phase four-wire grid-tie inverter system.

The body capacitors of the main MOSFETs and the output inductor L1 are combined to form a resonant circuit. The inductor current is intentionally bidirectional within a switching cycle to generate ZVS conditions during commutation. Meanwhile the average inductor current is controlled to produce a sinusoidal current in L1. The proposed soft-switching technique is suitable for MIC applications where the switching losses are usually dominant. Based on the above, Fig. 1 shows the proposed high-efficiency MIC architecture with both-stage zero-voltage switching consisting of a full-bridge LLC resonant dc-dc step up converter and three phase four-wire soft-switching dc-ac converter. The detail operating modes in the three-phase four wire dc/ac converter will be presented in the following sections.

#### Full Bridge LLC Resonant Converter

Secondary batteries are widely used in the application of residential, industrial, and commercial energy storage systems to store electricity and supply the load for various types of electronic equipment [1]–[7]. If the dc source is directly connected to the secondary battery, the output voltage of the dc source is fixed to the voltage of the secondary battery; therefore, the system cannot always operate at each optimum operating point. Therefore, it is necessary to install a dc-dc interface between the dc source and the secondary battery to make the energy storage system always operates at the optimum operating points. This dc-dc interface is also called the battery charger. The traditional battery charger, which extracts power from an ac-line source, requires a thyristor ac/dc converter rectifier with an equivalent series resistance to control the power flow to charge the battery system. Such a charging circuit necessarily draws a high-ripple charging current. Accordingly, as the concern about the quality of a charger grows, a charging circuit for reducing the ripple and extending the battery life becomes more important in designing the battery storage systems. Several charging circuits have been proposed to overcome the disadvantages of the traditional battery charger. Unlike linear regulators, switching regulators use active power switches to operate in either the saturation region or the cutoff region. Because either region will lead to low switching voltage or low switching current, it is possible to convert a dc voltage to a different level with greater efficiency, as well as with low cost, relatively small size,

and light weight between the two columns. The life and capacity of the secondary batteries depend on several factors e.g., charge mode, maintenance, temperature and age. Among these factors, the charge mode has a great impact on battery life and capacity. The secondary batteries should be charged with current and voltage levels with low ripple. Therefore, a high-performance battery charger is necessary in a battery energy storage system. In addition, the basic requirements of battery chargers with switching regulators are small sized and high efficiency. High switching frequency is necessary to achieve a small size. However, the switching loss will increase as the switching frequency is increased. This condition, in turn, decreases the efficiency of the battery chargers. To solve this problem, some kinds of soft-switching techniques need to be used to operate switching frequency. One simple solution to a soft-switching converter is loaded under high resonant converters. By adopting these topologies, either voltage or current is zero during switching transition, which largely reduce the switching loss and also increase the reliability for the battery chargers. To minimize the power losses, it is essential not to waste energy in the conversion process. In relation to the power electronics and associated control schemes, the main requirement is to guarantee that the charging system is efficient. Therefore, topologies with high frequencies and soft-switching technique are used to reduce the charging current ripple and extend battery life. Among these existing soft-switching converters, Resonant converters are the most popular ones because of their simplicity of circuit configuration, low switching losses, and high flexibility for charging current regulation. Resonant converters can be classified, depending on the manner by which energy is extracted from the resonant tank, into the following three types: 1) series resonant converters; 2) parallel resonant converters; and 3) series-parallel converters. The series resonant converter is inherently short circuit and protected by the impedance resonant tank. However, the drawback of the series resonant converter is that the charging voltage cannot be regulated at no load and light-load conditions. The disadvantage of the parallel converter is that the current in the resonant components is relatively independent of the load. The conduction losses are fixed, and the efficiency of the converter is relatively poor for light loads. On the other hand, the series-parallel converter combines the advantages of the series and parallel converters. The output is controllable for no load or light load, and the light load efficiency is relatively high. Accordingly, a series-parallel dc-dc converter is installed between the ac input source and the storage batteries to control the operating points of the dc source.

### **Operation Mode Of The Proposed ZVS Three Phase Four-Wire Dc/Ac Converter**

Because many articles about LLC resonant converters have been published over the last decade, this paper does not discuss it in great detail. The

operating modes of the proposed ZVS three-phase four-wire dc/ac converter is presented in this section. As shown in Fig. 3.1, the three phases of the dc/ac second stage are symmetrical around the neutral point; therefore, the analysis can be performed on a single phase as shown in Fig. 3 and described below.

Interval 1 [ $t_0 - t_1$ ]: Prior to  $t_0$ , S7 is off and S8 is still turned ON. Assume that the current direction through L1, as shown in Fig. 3, is already from right to left at  $t_0$ . Then S8 is turned OFF and the voltage across the parasitic capacitor CS8 of low side MOSFET S8 starts increasing due to the inductor current. As CS8 charges the voltage across S7 decreases. This interval ends once the voltage across S7 reaches zero. Interval 2 [ $t_1 - t_2$ ]: The body diode of S7 will be conducting at  $t_1$  and S7 can be turned ON with ZVS. The current flow decays linearly from right to left due to the fact that  $U_{bus}/2$  minus the voltage across L1.

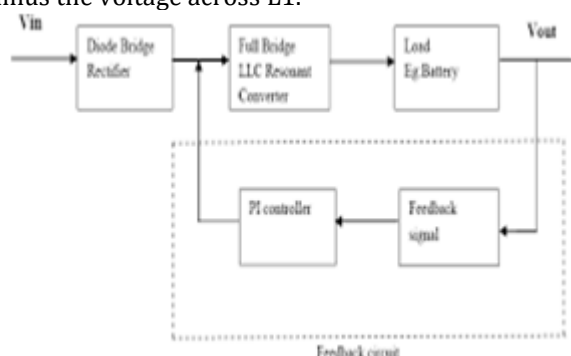
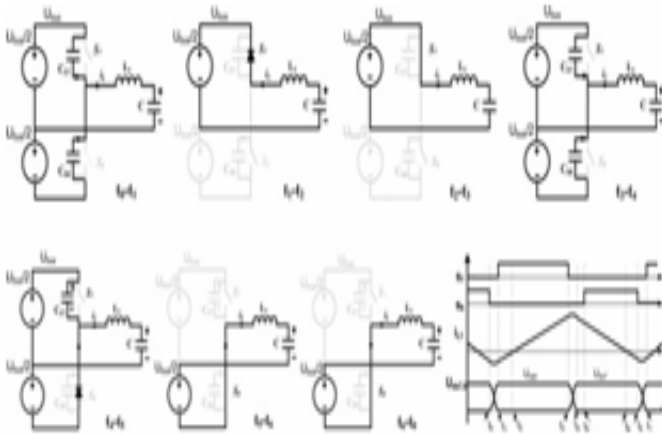

Fig3.2: Block Diagram Of Full Bridge LLC Resonant Converter For Battery Charging Application

This mode ends when the inductor current decays to zero. Interval 3 [ $t_2 - t_3$ ]: S7 is conducting and the current direction through L1 is now changed from left to right and increasing linearly. This is the power delivery interval. Interval 4 [ $t_3 - t_4$ ]: At  $t_3$ , S7 is turned OFF and its parasitic capacitor CS7 is charged by the inductor current while CS8 is discharging. Once the voltage across CS8 drops to zero, the parasitic body diode of MOSFET S8 conducts since the current direction through L1 does not change. Interval 5 [ $t_4 - t_5$ ]: Continuing from the previous interval 4, the body diode of S8 continues conducting which creates a ZVS condition when S8 is turned ON. The length of this interval is typically quite short and ends once S8 is turned ON. Interval 6 [ $t_5 - t_6$ ]: S8 is turned ON under ZVS condition at  $t_5$ . The current through S8 is gradually decreasing due to the fact that  $U_{bus}/2$  plus the output voltage appears across the inductor L1. During this interval the energy stored in the inductor is transferred to the load and the current that was flowing in the body diode of S8 now flows through the MOSFET on resistance thus reducing conduction losses. Interval 7 [ $t_6 - t_0$ ]: The current through S8 continues to flow and the current direction will change once the current decays to zero at  $t_6$ . Once the current through S8 changes direction from top to bottom as shown in Fig. 3.3, a ZVS condition is created for S7. When the current

through S8 reaches the negative threshold current, the cycle repeats.

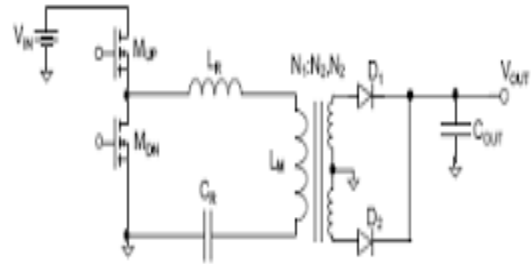

**Fig. 3. Theoretic waveforms and operating intervals of a single- phase dc/ac converter.**

**Interval 1: [t0 – t1 ], interval 2: [t1 – t2 ], interval 3: [t2 – t3 ], interval4: [t3 – t4 ], interval 5: [t4 – t5 ], interval 6: [t5 – t6 ], and interval 7: [t6 – t0 ].**

### Interleaved Three Phase LLC Resonant Converter

LLC Resonant converters exhibit large voltage ripple On output filter capacitor because of the rectified sine-wave current injected through the transformer secondary windings. In order to reduce the capacitor size and/or the steady-state output voltage ripple, the interleaved approach can be profitably applied. The benefit of an increasing number of parallel modules on the total rectified current ripple, that is the peak-to-peak ac current injected into the output filter capacitor. The results obtained from MATLAB Simulink Simulations with 400 V input voltage 24 V output voltage and different output currents. The huge reduction of total current ripple in the three modules solution can be appreciated as compared to one and two modules counterparts, suggesting the possibility. To drastically reduce the output filter capacitor size. the use of parallel connected LLC Resonant Converters to supply the same load and share the same output filter capacitor presents limitations and disadvantages caused by Resonant devices mismatch. The modules are operated at the same switching frequency controlled by the voltage regulation loop, while resonant component mismatch causes the three phases to exhibit different voltage conversion ratios. As a consequence, the load current is no longer equally supplied by the modules and one of the phases may totally reduce its output power to zero illustrates the results of some measurements on the prototype for different operating conditions. In presence of resonant device mismatch. in order to emphasize the mismatch the third module resonant capacitor has been increased by 12 % by adding A 2.7 Nf capacitor in parallel to the nominal one (22 Nf). It can be noticed from the data in the left- half of the table, that the third module delivers zero output current,



**Fig.3.4. Scheme of a single module LLC resonant converter.**

In presence of resonant component mismatch. This condition is confirmed by the inspection of the primary-side currents (400 V Input Voltage, 8 A output current conditions): The primary-side current of the third module is indeed interested only by the magnetizing current. In order to overcome such limitation, that is unavoidable in mass production, a three-phase topology is proposed, where the transformers primary windings are star connected. This modification allows, by means of the voltage modulation of star connection point, to greatly reduce the mean current unbalance caused by component mismatch. From data shown in the right-half of, the intrinsic balancing capability of this topology is pointed out compared to the simple parallel connection. Moreover, confirm the great balancing ability of the star connection topology compared to a simple parallel interleaved connection.

### CAPACITANCE CALCULATION OF DC- LINK CAPACITOR AND INPUT CAPACITOR

The dc/dc stage and dc/ac stage are decoupled due to the action of the dc-link capacitor, simplifying the controller design for both stages. Because of the three- phase dc/ac converter in the second stage, the value of the dc-link capacitor can be smaller for a given MIC power rating. Thus, the reliability of whole system will be significantly improved if the electrolytic capacitors are replaced by film capacitors. Although the capacitance value

**TABLE I  
 THREE-PHASE UNBALANCED DIPS DUE TO  
 DIFFERENT FAULT TYPES AND TRANSFORMER  
 CONNECTIONS**

Fault type	location of dip		
	I	II	III
Three-phase	A	A	A
Three-phase-to-ground	A	A	A
Two-phase-to-ground	E	F	G
Two-phase	C	D	C
Single-phase-to-ground	B	C	D

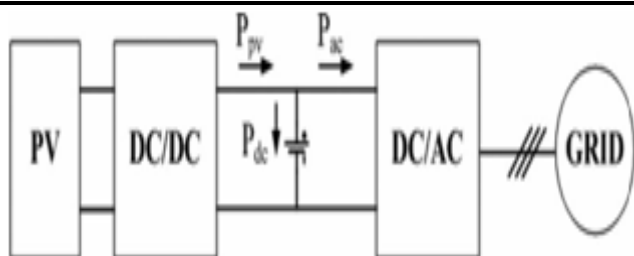

Fig. 15. Simplified block diagram of two-stage MIC

### Advantages of Full Bridge LLC

- Using Proposed Converter ( Full Bridge LLC ), we can expect Better Controllability than Half Bridge for wide voltage range.
- By adopting soft switching topologies, either voltage or current is zero during switching transition, which largely reduce the switching loss and also increase the reliability for the battery charger.
- It eliminates both low- and high-frequency current ripple on the battery, without using bulky filter capacitor, thus maximizing battery life without penalizing the volume of the charger.
- By use of closed loop control operation provides more accuracy and stability under the presence of nonlinearities.
- Resonant converter topologies can be used to increase circuit switching speeds, improved power factor and reduced switching losses.

### CONCLUSION

The closed loop control system of full bridge LLC Resonant Converter has been examined with help of MATLAB/SIMULINK. By using soft switching technique, both low- and high-frequency current ripple are destructed on the battery, thus maximizing battery life without penalizing the volume of the charger, and also reduce the switching loss. Stability is maintained by use of closed loop control operation, and provides more accuracy under the presence of non-linearity's. The High efficiency achieved with a constant output voltage The proposed topology is made by three half-bridge LLC converters with transformer primary windings star connection. This solution allows to drastically reducing the output current ripple compared to a single module, and exhibits an intrinsic balancing capability that is not common to other resonant interleaved solutions. Small- signal analysis of the proposed converter has been performed and a suitable digital control implemented. The possibility of turning off one or two phases depending on the overall output current level, is investigated, and the tradeoff between converter efficiency and output capacitor current ripple is discussed. The ZVS operating mode of the three-phase four-wire dc/ac converter is illustrated. Average modeling and hybrid control in the dc-ac stage are also discussed.

### REFERENCES

[1] European Photovoltaic Industry Association, Global market outlook for photovoltaics until 2016. (2012). [Online]. Available: [www.epia.org](http://www.epia.org)

[2] S. B. Kjaer, J. K. Pedersen, and F. Blaabjerg, "A review of single-phase grid-connected inverters for photovoltaic modules," IEEE Trans. Ind. Appl., vol. 41, no. 5, pp. 1292-1306, Sep./Oct. 2005.

[3] Y. Xue, L. Chang, S. B. Kjær, J. Bordonau, and T. Shimizu, "Topologies of single-phase inverters for small distributed power generators: An overview," IEEE Trans. Power Electron., vol. 19, no. 5, pp. 1305-1314, Sep. 2004.

[4] Lin Chen, Qian Zhang, Nasser Kutkut, "Design and Implementation of Three-Phase Two-Stage Grid-Connected Module Integrated Converter", IEEE Trans. On Power Electronics., vol. 29, no. 8, Aug 2014, PP. 3881-3892.

[5] J. Hepsy Joseph, R. M. Sekar, J. Velmurugan, "Closed Loop Control of Full Bridge LLC Resonant Converter for Battery Charging Application", „IOSR Journal of Electrical and Electronics Engineering", ISSN 2278-1676, p-ISSN: 2320-3331, vol. 9, Issue 1 Ver. IV (Feb. 2014), PP. 91-99.

[6] A. Hillers, D. Christen and J. Biela, "Design of a Highly Efficient Bidirectional Isolated LLC Resonant Converter", „15th International Power Electronics and Motion Control Conference, EPE-PEMC 2012 ECCE Europe, Novi Sad, Serbia"

[7] E. Orietti, P. Mattavelli, G. Spiazzi, C. Adragna, G. Gattavari, "Analysis Of Multi-Phase Llc Resonant Converters", Dept. of Information Engineering - University of Padova

[8] E. Roman, R. Alonso, P. Ibanez, S. Elorduizapatarietxe, and D. Goitia, "Intelligent PV module for grid-connected PV systems," IEEE Trans. Ind. Electron., vol. 53, no. 4, pp. 1066-1073, Jun. 2006.

[9] [http://en.wikipedia.org/wiki/Stock\\_market](http://en.wikipedia.org/wiki/Stock_market)

[10] <http://biz.yahoo.com/p/>

[11] <http://en.wikipedia.org/wiki/MATLAB>

### Authors



**Mr. Bhooshan Deelip Darkonde**  
 received B.E. in Electrical Engg. from Rajiv Gandhi College of Engg and Technology, Chandrapur. Tal- Chandrapur, Dist- Chandrapur (Maharashtra)



**Prof. Prabhodhkumar Khampariya** Head of the Department of Electrical Engg., SSSIST Sehare (MP)