

MPPT OF PV CELL USING P & O AND FUZZY LOGIC CONTROLLER ALGORITHM FOR BUCK-BOOST DC-DC CONVERTER

RAHUL S. SHARMA,

M Tech student, Electrical Engg, department, Dr. B.A.T.U, Lonere (India) , Email: rahsha17@gmail.com

BALAJI R. JADHAV,

Instrumentation engineering, MBES college of engg., Beed, Email: brjadhav2@gmail.com

ABSTRACT:

Non-conventional power generation is one of the fastest growing sectors. Globally, all countries are busy developing and implementing non-conventional power to bridge the electricity demand and power supply gap. The sun is the ultimate source of limitless solar energy in the form of light and heat. Light of the sun is directly converted into electrical energy without any inter mediate step.

Solar photovoltaic (PV) power is leading ahead of the other sources. In a solar power generation system, the PV cell plays a major role.

Rural coastal communities in developing countries along the equator lack electricity, due to the expenses involved with connecting them to the power grid. An affordable local solution, such as on-site micro power generation, would benefit the local communities and fulfill their basic lighting and ventilation needs. Equatorial coastal areas have constant high incident solar radiation. Therefore, these regions would be ideal to implement a solar power generation unit. This project involves the development of a solar panel to generate direct current (DC) power that will be used to charge a battery. And this DC voltage from battery is converted into AC using inverter. This system will provide the basic electricity requirements for the house.

KEYWORDS: Perturb and Observe algorithm, DC-DC buck boost converter, fuzzy controller, MPPT etc.

INTRODUCTION:

Energy plays vital role for development in all sectors. With depletion of fossil fuels used for power generation and increase in demand for power, the gap between supply and demand is becoming more. Renewable energy sources can only provide solution to face this energy crisis. Out of renewable energy options, solar energy is the most potential source for all tropical countries. Sun radiates 180 billion MW of energy over Earth just one hour of this energy could meet power needs of entire planet for a year. India receives 5000 Trillion kw/hrs of energy from SUN per annum. This

energy is clean, pollution free and inexhaustible and is available free and in abundance. MNRE, Government of India is promoting utilization of the solar energy for different applications since 1980's.

Basically the components involved in solar system are PV panel, DC-DC Converter, Battery, Inverter. The Same components are present in our system with some additional accessories to improve the overall performance of the system. Efficiency of the system can be drastically increase by using microcontroller for PWM control in place of PWM generator hardware circuit.

The initial investment may be excessive for the target population, these costs are expected to go down if the design is mass-produced. Solar power source is "free" making this system is a viable long-term solution for electrification. The implementation of a project such as this will make the use of hazardous items such as kerosene lamps and car batteries redundant. Purpose of investment in solar power project is to enter in development of green energy technology, which is the only ultimate source of energy for future generations.

LITERATURE REVIEW:

Energy is the key influencing factor for development in all sectors i.e., Industrial, Commercial, Agriculture, Domestic etc. as per capita energy consumption is one of the indicators of national development status. per capita energy consumption is about 600 units in our country, where as it is 1400 units in China, 6898 units in Germany, 13,000 units in U.S.A. World average is about 2430 units.

India is the sixth largest Country in the world in terms of generation and consumption levels. The total installed capacity of Power projects India is 1,47,402.81 Mega Watts , of this thermal mode of power generation including coal, gas and oil contributes 64.7%, Hydro contributes 24.65%, Nuclear 2.95% and Renewable energy 7.7 The present national peak deficit stands at 10.1%. Ministry of power had decided to add about 52,598 MW capacities for the XI plan (2008-2012). Continuous development of the Generation Sector is essential for meeting the GDP growth target of 8% set for the Economy. In Order to support the envisaged growth of GDP, the rate of growth of power supply needs to be

over 9.5 percent annually. The demand-supply gap', which is denoted as 'energy shortage' is 8.8% of the total energy requirement in 2009 and the peak shortage, which is a measure of shortage during peak power consumption hours is approximately 14 percent of installed capacity. To meet the projected demand of 2016, generation capacity is required to be doubled in 10 years from 2006 to 2016. The Government of India has initiated several reform measures to create a favorable environment for addition of new generating capacity in the country. The Electricity Act 2003 has put in place a highly liberal framework for generation. There is no requirement of licensing for generation and techno-economic clearance from CEA for thermal generation projects.

The fast diminishing world reserves of fossil fuels, increasing demands for energy, particularly in developing countries, and the damage to the environment caused by the consumption of large quantities of fossil fuels in the preceding century have encouraged intensified search for renewable and environment friendly sources of energy.

The use of renewable energy resources involves the tapping of natural flows of energy in the environment. If the resource is used in a sustainable fashion, the energy is removed at a rate comparable to that at which energy is being replenished. Renewable energy is thus inexhaustible as opposed to conventional sources of energy, which has a limited lifespan.

The use of conventional sources of energy such as fossil fuels has many adverse side effects. Their combustion products produce pollution, acid rain and global warming which are currently major global concerns. Conversion to clean energy sources can improve the quality of life throughout the planet earth, not only for humans, but for its flora and fauna as well. Consequently, the use of renewable energy can contribute to environmental protection not only for the present generation but for future generations as well.

Because of the foregoing, there is a need to develop ingenious methods of renewable energy conversion systems and then to substitute it where applications of fossil fuels are most vulnerable. With renewable energy technologies, a secure and diverse supply of energy can be secured and resources can be restored. Additionally, renewable energy is widely distributed and is available and indigenous to almost every region of the world. Currently, the worldwide renewable percentage contribution is about 18%. By the year 2020, the World energy Council predicts that the contribution from renewable will rise to 30% and that biomass will continue to be the dominate source of renewable energy.

DISADVANTAGES AND LIMITATIONS OF CONVENTIONAL ENERGY SOURCES:

- Resources are limited.
- Environmental problems, emission of greenhouse gasses.
- Dependency on imports.
- Dependency on global oil prices, which effects country economy.
- Transmission & distribution losses

To improve the situation and to achieve world average per capita energy consumption of 2500 units there is need for tapping alternative sources of Energy. The following are the key factors for taping and utilization of alternative renewable energy sources.

- Conservation of limited conventional energy resources which can be made available for futuristic generation.
- Reducing imports and avoided cost can be invested for other developmental activities.
- Reduction of G.H.G and other emissions for protecting environment.
- Use of in-exhaustible energy sources like Solar, Wind, Biomass, Tidal etc.

RENEWABLE ENERGY SCENARIO:

Renewable Energy accounts for about 7.49% of the total installed capacity of the country (as on 31-10-2009) for power generation. The potential of various renewable energy sources and actual achievement is as under.

Sr. No	Source	Estimated potential (MW)	Installed capital (MW)
1.	Wind	45000	10891
2.	Biomass	61000	816
3.	Small Hydro	15000	2519
4.	Waste of energy	7000	67
5.	Solar Photovoltaic	9566.66	8

EQUIVALENT CIRCUIT OF PV ARRAY:

The solar cell is basically a p-n semiconductor junction that directly converts light energy into electricity based on photoelectric effects. PV cells grouped in larger units form a PV module and interconnection of more PV modules in a equivalent circuit shown in Fig.No. 1.

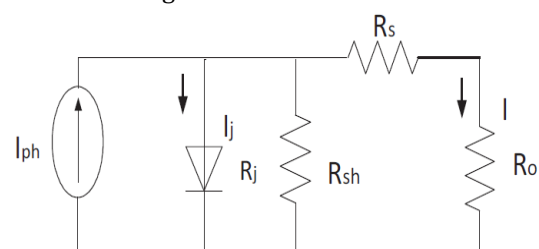

Fig.No.1. Equivalent circuit of PV cell

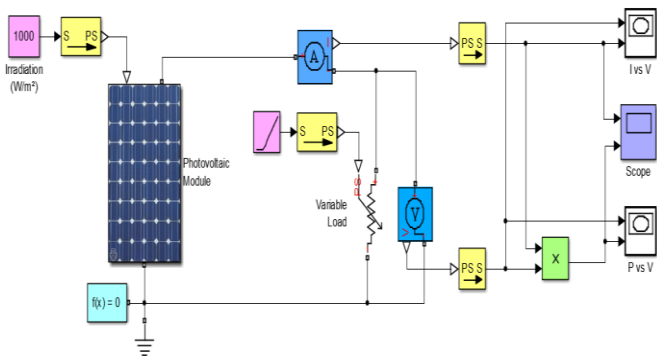

Fig. No.2. Implemented PV cell model in MATLAB simulink

Simulation of PV array was done by doing step variations of S and T. The I/V and P/V characteristics through simulation are shown in Fig.no.3 & 4

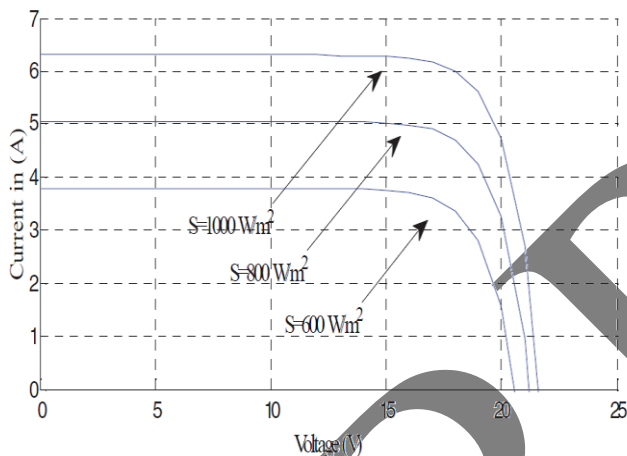

Fig. No.3. IV characteristics of PV module from MATLAB simulation

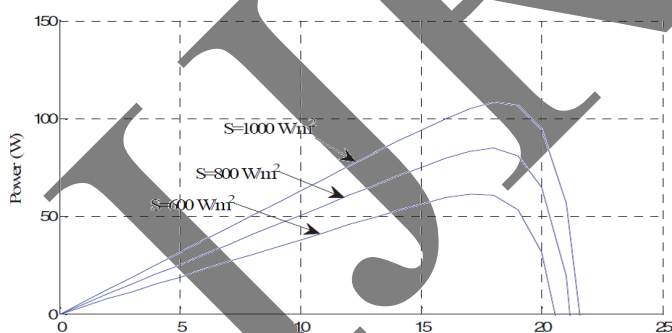

Fig. 4. PV Characteristics of PV module obtained from MATLAB simulation

MAXIMUM POWER POINT TRACKING(MPPT) – P & O METHOD:

- Open voltage method.
- Short current method.
- Perturb and observe method.
- Incremental conductance method

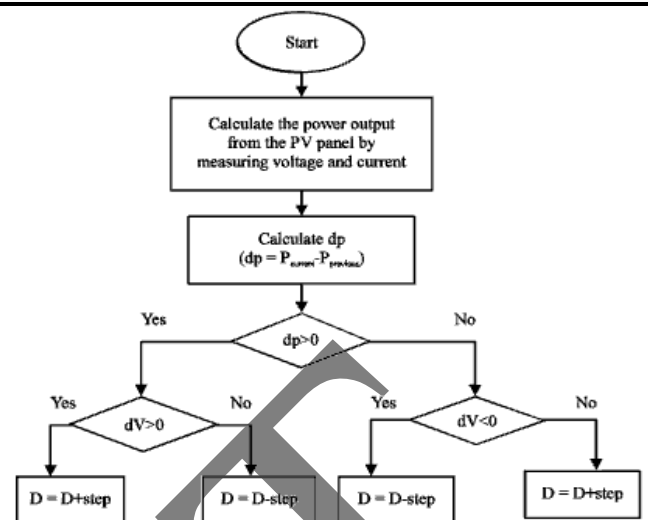

Fig.5 :- perturb and observe flowchart algorithm

The P&O algorithm is also called “hill-climbing”, while both names refer to the same algorithm depending on how it is implemented. It is one kind of hill climbing algorithm. While hill climbing takes place perturb duty cycle of power converter does the alteration in Dc link voltage amongst power converter and PV array. If there is an increment in the power, the perturbation should be kept in the same direction and if the power decreases, then the next perturbation should be in the opposite direction. Based on these facts, the algorithm is implemented. The process is repeated until the MPP is reached. Then the operating point oscillates around the MPPT.

FUZZY LOGIC MPPT CONTROLLER:

In the last decade MPPT for PV array's have been influenced by the good research content. The best advantage of FLC is it does not need the awareness of PV module system. Moreover it can be used for linear and non linear system as well. The fuzzy controller functional block for implementation of this algorithm is as shown in Fig.6

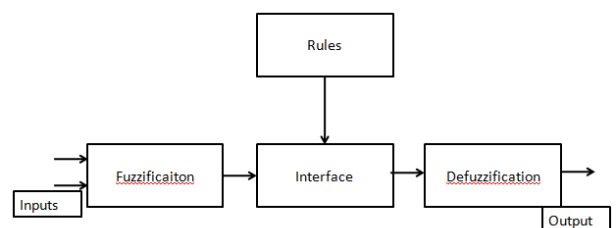

Fig. no. 6. Block diagram of fuzzy logic controller

The fuzzy logic based MPPT techniques is shown fig. 7 with two inputs and one output. The input variables are current and current -1 stage and output variable is duty cycle. Membership functions (MF) of input variables, output variable and the proposed FLC algorithms are shown in Fig.7, Fig.8, Fig.9 and Fig.10

respectively. Very Small (VS), Small (S), Medium (M), High (H), Low (L) and Very Low(VL)

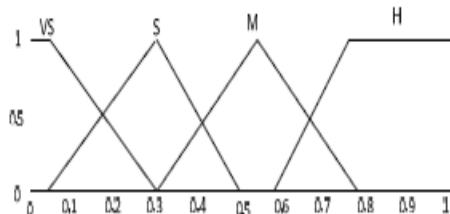

Fig. No.7. MF of input variables

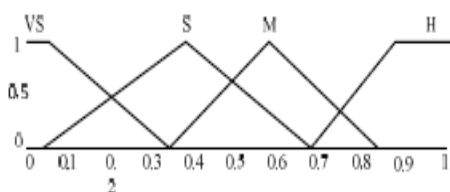

Fig. No.8. MF of input variables

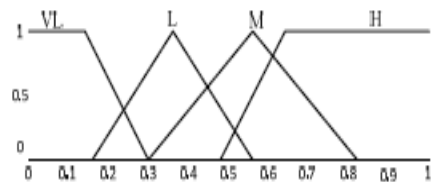

Fig. No.9. MF of output variables

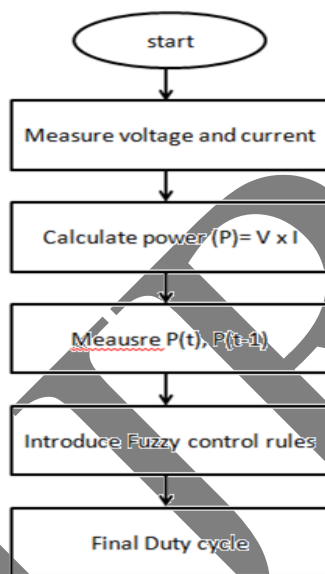

Fig. 10. The proposed Fuzzy logic algorithm

The fuzzy control rules as given in Table-I was done with Mamdani Methods and the defuzzification was done with the centre of gravity method to calculate the out of FLC (duty cycle).

Table no.1. fuzzy control rules

P(T- 1)\ P(T)	VS	S	M	H
VS	VL	L	M	L
S	L	M	H	M
M	M	M	M	H
H	H	M	H	M

**DC-DC BUCK BOOST CONVERTER:
BUCK BOOST CONVERTER:**

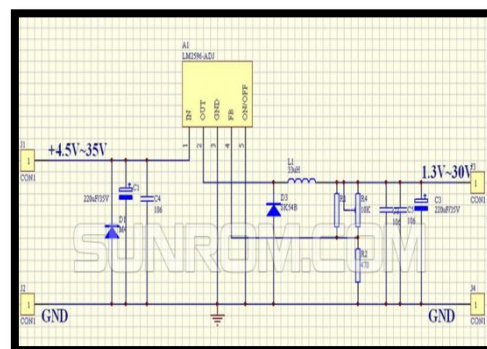

Fig.11:- buck boost converter circuit

1. The main components of buck boost converter are inductor, power MOSFET, two capacitors and a diode.
2. Power MOSFET is used as a switching device and it connects inductor and solar panel. Input gate pulses to the mosfet for it is given from the external circuitry. Which is explained in later section? Inductor is directly connected to load.it is used as storage device.
3. Input capacitor is connected parallel to the solar panel and output capacitor is connected parallel to the load (battery).both this capacitor is used as filtering device to removes voltage fluctuations and spikes.
4. Diode is connected between ground and branch connecting inductor and mosfet.it works as freewheeling diode.

CONCLUSION:

While implementing this paper PV and IT characteristics of PV module using solar panel is been modeled by using MATLAB simulink. While plotting PV and IV characteristics solar insolation and temperature of the cell is taken care. The MPPT technique using buck-boost, conventional P & O and fuzzy logic controller, all these techniques is being implemented in MATLAB simulink environment purely for the comparison. From the obtained test results author would like to conclude that fuzzy logic technique is more efficient and produces optimized duty cycle for PV array MPPT technique.

REFERENCES:

- 1) Syafaruddin; Karatepe, E.; Hiyama, T., "Artificial neural network-polar coordinated fuzzy controller based maximum power point tracking control under partially shaded conditions," IET Renewable Power Generation, vol.3, no.2, pp.239,253, June 2009.
- 2) Chao, PaulC.-P. and Chen, Wei-Dar and Chang, Chih-Kuo, 'Maximum power tracking of a generic photovoltaic system via a fuzzy controller and a two-stage DC-DC converter', Microsyst. Technol., 2012, 18, pp. 1267-1281

- 3) Hussein, K.H.; Muta, I.; Hoshino, T.; Osakada, M., "Maximum photovoltaic power tracking: an algorithm for rapidly changing atmospheric conditions," Generation, Transmission and Distribution, IEE Proceedings- , vol.142, no.1, pp.59,64, Jan 1995.
- 4) ANGRIST, S.W.: 'Direct energy conversion' Aunyn and Bacon, 1971, 2nd edn, pp. 190-200
- 5) Vachtsevanos, G.; Kalaitzakis, K., "A Hybrid Photovoltaic Simulator for Utility Interactive Studies," Energy Conversion, IEEE Transactions on , vol.EC-2, no.2, pp.227,231, June 1987.
- 6) Faranda,R.,Leva,S.: "Energy Comparison of MPPT techniques for PV systems," WSEAS Transaction Power Systems.,2008,3.pp.446-455.
- 7) Mohd Zainuri, M.A.A.; Mohd Radzi, M.A.; Soh, A.C.; Rahim, N.A., "Development of adaptive perturb and observe-fuzzy control maximum power point tracking for photovoltaic boost dc-dc converter," IET Renewable Power Generation,, vol.8, no.2, pp.183,194, March 2014
- 8) Subudhi, B.; Pradhan, R., "A Comparative Study on Maximum Power Point Tracking Techniques for Photovoltaic Power Systems," Sustainable Energy, IEEE Transactions on , vol.4, no.1, pp.89,98, Jan. 2013.
- 9) Thomas Bennett, Ali Zilouchian, Roger Messenger, "Photovoltaic model and converter topology considerations for MPPT purposes," Solar Energy, Volume 86, Issue 7, July 2012
- 10) Coelho, R.F.; Concer, F.; Martins, D.C., "A study of the basic DC-DC converters applied in maximum power point tracking," Power Electronics Conference, 2009. COBEP '09. Brazilian , vol., no., pp.673,678, Sept. 27 2009-Oct. 1 2009.
- 11) Chihchiang Hua; Chihming Shen, "Comparative study of peak power tracking techniques for solar storage system," Applied Power Electronics Conference and Exposition, 1998. APEC '98. Conference Proceedings 1998., Thirteenth Annual , vol.2, no., pp.679,685 vol.2, 15- 19 Feb 1998.
- 12) Alqarni, M.; Darwish, M.K., "Maximum power point tracking for photovoltaic system: Modified Perturb and Observe algorithm," Universities Power Engineering Conference (UPEC), 2012 47th International , vol., no., pp.1,4, 4-7 Sept. 2012.
- 13) Wu, Y., Zhang, B., Lu, J., Du, K.L.; 'Fuzzy logic and neuro-fuzzy system: a systematic introduction', Int. J. Artif. Intell. Expert Syst. (IJAE), 2011, pp. 47-80.
- 14) [14] Noman, A.M.; Addoweesh, K.E.; Mashaly, H.M., "An intelligent FLC method for tracking the maximum power of photovoltaic systems," Electrical and Computer Engineering (CCECE), 2014 IEEE 27th Canadian Conference on , vol., no., pp.1,8, 4-7 May 2014 .
- 15) C. Larbes, S.M. Aït Cheikh, T. Obeidi, A. Zerguerras, "Genetic algorithms optimized fuzzy logic control for the maximum power point tracking in photovoltaic system," Renewable Energy, Volume 34, Issue 10, October 2009.
- 16) Syafaruddin; Karatepe, E.; Hiyama, T., "Artificial neural network-polar coordinated fuzzy controller based maximum power point tracking control under partially shaded conditions," IET Renewable Power Generation, vol.3, no.2, pp.239,253, June 2009.
- 17) Chao, Paul C.-P. and Chen, Wei-Dar and Chang, Chih-Kuo, 'Maximum power tracking of a generic photovoltaic system via a fuzzy controller and a two-stage DC-DC converter', Microsyst. Technol., 2012, 18, pp. 1267-1281
- 18) Coelho, R.F.; Concer, F.M.; Martins, D.C., "Analytical and experimental analysis of DC-DC converters in photovoltaic maximum Power Point Tracking applications," IECON 2010 - 36th Annual Conference on IEEE Industrial Electronics Society , vol., no., pp.2778,2783, 7-10 Nov. 2010.