

GSM BASED SECURITY SYSTEM USING MICROCONTROLLER

NALE DIVAKAR DIPAK

Karamayogi Engineering College Shelave, Pandharpur 413304

TAMBADE VARSHA

Karamayogi Engineering College Shelave, Pandharpur 413304

PROF. SHIVPUJE D.B.

(M.E. E&TC), Karamayogi Engineering College Shelave, Pandharpur 413304

ABSTRACT

Security and automation is a prime concern in our day-to-day life. Everyone wants to be as much as secure as possible. Due to the inefficient system security problems are increases. Manual operated system may not be give hundred percent security. GSM based security system is fully automized and efficient syst, designed with the help of Microcontroller.

In this system various types of alert signals are generated by the system, given to the owner as well as another person or system like police on their cell phones. With the help of this system we gets alert signal on our mobile phone. So this system reduces mainly efforts to carry any another object for getting an alert signals. This process is take the action with in the fraction of the second. We needs security at every place like Bank at home or apartment and also at office cabin ,shops, farms, parkingetc.

With the help of GSM module system is transmit the alert signals to the owner. This system is applicable at every place where we need more security with the help of this system we can easily Find out who is entered in secure zone. With the help of CCTV camera system. This system is avoid extra use of energy using atomization.

KEYWORDS: IR (Infra Red)Sensor, GSM(Global System for Mobile) Module, Microcontroller, PIR(Passive Infra Red) Sensor ,CCTV(Closed Circuit Tele Vision)camera , Relay,

INTRODUCTION

In day today life we required more security so in market there is number of products are available like CCTV camera system, buzzer system etc. But this systems are not gives that much efficiency and also alert signals which are not useful when owner is not present at high alert area so we are work on that and design such type of system. i.e. GSM Based Security

System which gives alert signal to particular owner of the system on their mobile phone by using GSM System. System can call more than one person so this system gives more efficiency in security application. An automatically calling process is done when any person or object is detected by the system, With the help IR trance receiver sensor then it gives 5V DC voltage at output pin of the sensor which is connected

to the controller as a input device. Function of the controller is to continuously check the inputs coming from the different sensor and send message through the GSM network in case of emergency. The microcontroller is connected to different devices like PIR sensor , Relay driver board GSM Module , buzzer .When any persone is entered in the secured zone then also detected by PIR sensor generate signal and gives to controller and controller on the lights of that secured room and also switch on the CCTV Camera system which stats capturing videos and storing into the memory and simultaneously it show on window also if it is connected in system this whole process is done with the help switching of the relay driving board by the controller. Programmed microcontroller has been connected to the interface circuit and the GSM MODEM through the serial port of the GSM MODEM .When the user is away from secured zone, all the sensors are activated by switching on the Security system.

EXISTING SYSTEMS

1. Wired System,
2. RF Based Security System,
3. Web enabled Security System.
4. Applicable or suitable for particular area like bank

DISADVANTAGE OF EXISTING SYSTEMS

1. Difficult to maintain
2. Need internet access
3. Distance.
4. No any type of provision to give the massage touser
5. System kept continuously cameras and lights on.

PROPOSED SYSTEM

The proposed system uses GSM module which enables us to know the security status of secured area when we are away from the secured. System keeps record in form video clips what exactly happen in secured area in the absence of user.

MICROCONTROLLER

MCS51 is family of 8-bit microcontroller by INTEL designed around HMOS technology. Operating frequency is 12MHz. Available 32 I/O lines can be used as four 8 bit ports. There are two other members of family i.e.8051,8052,,8031. Micro controller is 40 pins dual in package IC. PORT 3 acts as Multi functional PORT.

GSM MODULE:

On GSM modem board consist of serial communication MAX 232 IC , for good serial communication with controller . It having trance receiver unidirectional antenna. Which transmit and receive signals from mobiluser.

GSM module consist of one notch in that we can insert the SIM(Subscriber Identity Module).

It is used to store the confidential and personal information about the subscriber.

This information stored on SIM is protected by the unique number called as PIN.

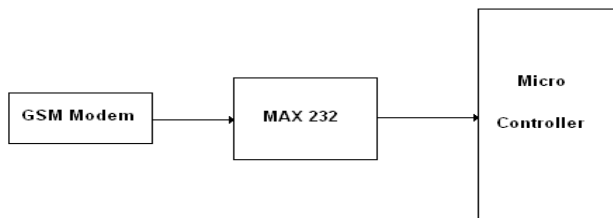

Fig. GSM(Global System For Mobile) MODULE.

A Global System For Mobile (GSM) is most popular mobile communication standard which is typically second generation (2G) Digital Wireless Network standard.

Due to the advancement radio communication, the GSM is developed to provide the services such as voice, data and multimedia services to the mobile user. The main aim of GSM is to provide services that are not time, location land, format dependent.

GSM digitizes and compresses data, then sends it down a channel with two other streams of user data, each in its own time slot. It operates at either the 900 MHz or 1800 MHz frequency band. The GSM module is communicate the microcontroller with mobile phones through UART.

IR TRANCE-RECEIVER SENSOR

This is main and important component in the security system .Sensor plays very important Roll in this system. It acts as one hidden watchman which is not visible to any robber or any person and also location for this sensor is always near to the secure zone when we should have security. Sensor is continuously check any person or object is coming or not in the secure zone.

If any Object or Person is detected that means any person is come in secured zone so the sensor creates some output voltage in DC voltage at output pin.

This sensor consist of the important feature is this sensor can be directly connect or interface to micro controller 6dIC8051.Because of output is in the form of DC voltage.

This sensor gives more efficiency. In this sensor uses two diodes first is IR LED and second is PHOTO DETECTORDIODE this both the diodes are mounted inside this sensor hence this sensor is known as IR TRANCERECEIVER SENSOR.IR LED which transmit IR light

rays continuously in forward direction which not visible to human eye. When this light ray is cut by any object or person the this light ray is reflected in backward direction towards transmitter side where one photo detected is already mounted in sensor. This diode is detect the light ray and generates some voltage or current that means photo detector diode is goes in forward bias mode when IR light ray is fall on that diode .This sensor is input device which gives 5v pules to controllerIC8051. It required only +5v DC power supply for operation. It required +5v DC power supply .IT does not require extra any hardware for interfacing with micro controller 8051 I This sensor is light in weight and small in size Range of operating is adjustable up to 50 cm. No any complicated circuit is required. It gives higher efficiency. It having only three wires one for +vcc, second for output of sensor, third is GND. Maintenance cost is very low.

PIR (PASSIVE INFRA RED)SENSOR

This sensor is work on the temperature, means with the help of changing temperature of room after entering person is detected by the PIR sensor and generate output signal. This sensor is basically used for determine that any person is entered or not in secure zone.

RELAY DRIVER BOARD

This is the automatic switching circuit board work on the 12V DC voltage after receiving voltage from the controller it switch on automatically using relay i.e. nothing but the automatic electrical switch.

POWER SUPPLY

For working of the system required +12 V DC power supply. It having inbuilt Step Down transformer, Rectifier circuit, Filter and regulator circuits. Sequentially Her one adapter is used for power supply, which gives required voltage levels.

BLOCK DIAGRAM

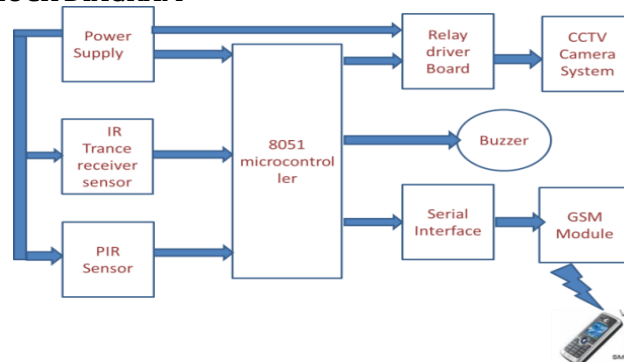

This circuit is mainly divided into three different sections. First sensor section at beginning stage, second is controller section at middle stage and third is GSM section at the last stage.

First we see the the working of beginning stage i.e. sensor section in this section main component is sensor. Sensor is nothing but an input device. This connected with middle stage.

It having two input terminals vcc and Ground and one output terminal. The basic principal of working of sensor section is power supply is provided by two terminals to the sensor which transmit IR light signal in forward direction if any object or person is come in front of sensor it will produces five volt DC voltage at output terminal which is connected with next stage .

Next stage is controller section output terminal is connected to interrupt pin no 13 of the controller

IC and program file is burned in to that IC and assigning work by using command when input at pin no 13 is high or logic 1 then send the calling number to GSM Module which is stored in controller ICs memory for calling user by using two serial communication pins i.e. TXD and RXD. middle stage is communicate with last stage i.e. GSM section TXD pin of controller IC is connected to RX pin of GSM and RXD pin of controller is connected with TX pin of GSM

Number is coming from controller through TXD pin is received by using RX pin in that two pins serial communication is happens and vice a versa .For proper serial communication in between TXD and RX line MAX 232 IC is used. After receiving user mobile number from controller GSM module is call on the given number. And buzzer is on continuously when input is high at pin no 13. In this way all system is works

RESULTS

In this system after hardware and software implementation we observed that when any object is cannot in front of sensor that means system check and recognized that no any object or person is present at secured area. When any object is come in front of sensor it is detected that any object or person is found at secured area. Sensor creates 5V DC output voltage which is interrupted to microcontroller, controller on the buzzer continuously and forwarding the call to user through GSM automatically and person is detected by the PIR sensor then relay is on which is on the CCTV camera as well as room light system.

CONCLUSION

This system is designed for applicable at every where to give high efficiency of output and easy to maintain and economically cost effective

REFERENCES

- 1) System", IEEE International Conference, ISBN: 0-7803-8482-2, (2004) 237-238.
- 2) Ying-Wen Bai, Shi-Chang Chen, Fu Jen, "Design and Implementation of Home Intercom and Security Control Systems for Buildings" Catholic Univ. Information.
- 3) T. Begum, M. S. Hossain, M. B. Uddin, and M. S. H. Chowdhury, "Design and development of activation and monitoring of home automation system via SMS through microcontroller," in Proc. 2009 4th International Conference on Computers and Devices for Communication (CODEC 2009), Kolkata, pp.1-3.
- 4) B. I. Ahmad, F. Yakubu, M. A. Bagiwa, and U. I. Abdullahi. (2011). Remote Home Management: An alternative for working at home while away. World of Computer Science and Information Technology Journal (WCSIT), 1(4), pp. 144-147.
- 5) A. W. Ahmad, N. Jan, S. Iqbal, and C. Lee, "Implementation of ZigBee-GSM based Home Security Monitoring and Remote Control system," in Proc. 2011 IEEE 54th International Midwest Symposium on Circuits and Systems (MWSCAS), Seoul, pp.1-4.
- 6) K. Gill, S. -H. Yang, F. Yao, and X. Lu. (2009). A zigbeebased home automation system. IEEE Transactions on Consumer Electronics, 55(2), pp.422 - 430.
- 7) L. Pu, "An Improved Short Message Security Protocol for Home Network," in Proc. 2009 International Conference on Future Computer and Communication (FCC '09), Wuhan, pp.62-65.
- 8) Fabian Winkler," Arduino workshop", spring 2007, [http:// www.arduino.cc](http://www.arduino.cc).
- 9) The Smart Detect Project Team, "Wireless Sensor networks for Human Intruder Detection", Indian institute of Science, Bangalore, India, May 2010.
- 10) V. Karri and J. S. Daniel Lim, "Method and Device to Communicate via SMS After a Security Intrusion", 1st International Conference on Sensing Technology, Palmerston North, New Zealand, (2005) November 21-23.
- 11) Y. Zhao and Z. Ye, "Low cost GSM/GPRS BASED wireless home security system", IEEE Trans. Consumer Electron, vol. 56, no. 4, (2007) January, pp. 546-567.