

SOLAR POWERED WATER TRASH COLLECTOR

¹Prof. Trupti M. Kulkarni,

²Aditi S. Yadav,

³Vaishnavi R. Sangitrao,

⁴Rutuja A. Vasekar,

⁵Sakshi S. Adsul

¹Assistant Professor, Department of E&TC Engineering

^{2,3,4,5}Students, Department of E&TC Engineering
Karmayogi Institute of Technology, Shelve, Pandharpur, India

Abstract

Water pollution caused by floating waste such as plastic bottles, wrappers, and other debris is a major environmental concern in rivers, lakes, and ponds. The Solar Powered Water Trash Collector is designed to automatically collect floating waste from water surfaces using renewable energy. The system uses solar panels to generate electrical energy, which powers DC motors through a motor driver to move the collector and operate the collection mechanism. The collected waste is stored in a container attached to the system. This project helps reduce manual effort, saves energy, and promotes eco-friendly waste management. The proposed system is cost-effective, sustainable, and suitable for maintaining cleanliness in small water bodies.

Keywords: Solar panel, Water pollution, Floating waste, Waste management.

INTRODUCTION

Clean water bodies are essential for maintaining a healthy environment and supporting aquatic life. However, many rivers, lakes, and ponds are becoming polluted due to the accumulation of floating waste such as plastic bottles, bags, and other debris. This waste affects the ecosystem and create serious environmental problems. To address this issue, an automated system called a Solar Powered Water Trash Collector is proposed. The system is designed to collect floating waste from the water surface using DC motors powered by a solar panel. The collected waste is stored in a container for proper disposal. This project aims to provide an efficient and eco-friendly method for keeping water bodies clean.

1. DEFINITION

The Solar Powered Water Trash Collector is an automated system designed to remove floating waste from water bodies such as rivers, lakes, and ponds by using solar energy as its main power source. It uses solar panels to generate electricity, which powers electronic components like a microcontroller, DC motors, and a conveyor mechanism to collect and store floating trash in a container, helping to keep water bodies clean in an eco-friendly and energy-efficient way.

2. PURPOSE

The purpose of the Solar Powered Water Trash Collector is to reduce water pollution by automatically collecting floating waste such as plastic bottles, wrappers, and debris from water bodies like rivers, lakes, and ponds. The system uses renewable solar energy to operate, which helps reduce fuel consumption, human effort, and environmental impact while maintaining cleaner aquatic environments.

3. METHODOLOGY

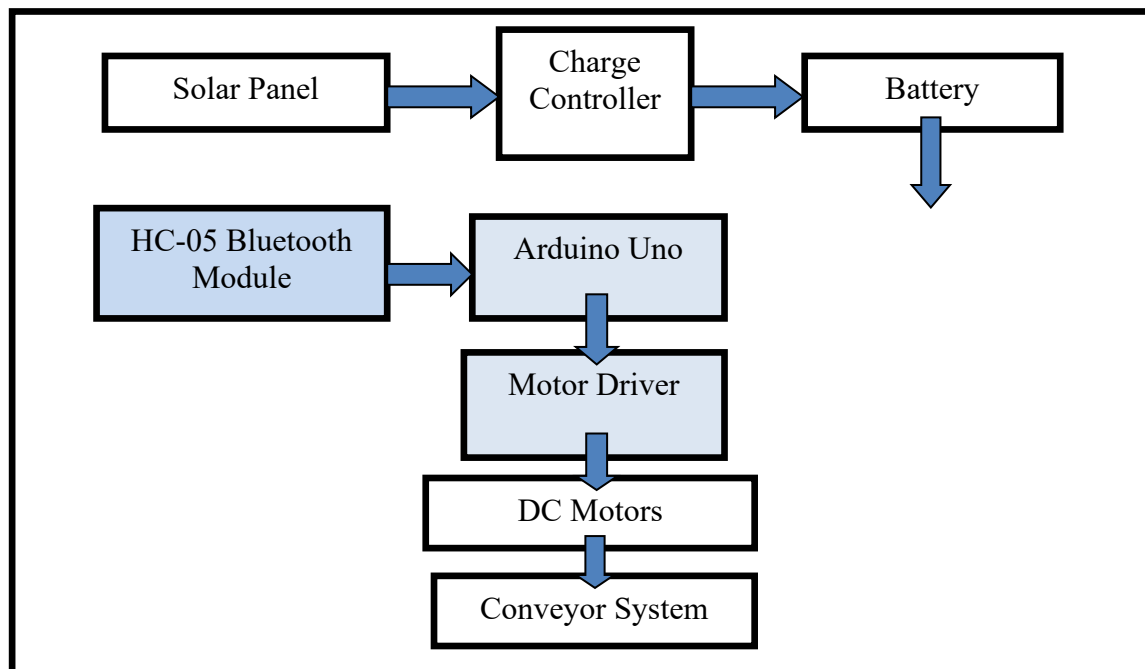

The methodology of this project involves designing a floating boat-like structure powered by solar energy. A solar panel converts sunlight into electrical energy and charges a rechargeable battery. The stored energy powers an Arduino Uno microcontroller, DC motors, and a conveyor belt mechanism. As the device moves on the water surface, the rotating conveyor collects floating trash and transfers it into a storage container. The system is operated manually using Bluetooth module.

4. NEED OF STUDY

1. To reduce water pollution caused by floating waste.
2. To protect aquatic life from harmful plastic debris.
3. To reduce dependence on manual cleaning methods.
4. To minimize the use of fuel-powered machines.
5. To promote eco-friendly waste management.

5. OBJECTIVES

1. To design and develop a solar powered water trash collector.
2. To collect floating waste from water bodies efficiently.

3. To use renewable solar energy for system operation.
4. To reduce human effort in water cleaning.
5. To maintain cleaner and healthier water environments.

6. SCOPE OF STUDY

The project aims to develop a solar powered water trash collector to remove floating waste from the surface of water bodies such as ponds, lakes, and small rivers. The system focuses on collecting lightweight floating materials like plastic bottles, wrappers, and other debris. It operates using solar power and basic electronic components such as DC motors and a motor driver. The project mainly demonstrates an eco-friendly method for reducing water pollution in small water bodies.

References

- [1] D.Venkata Lakshmi et al., Solar Powered Water Trash Collector, International Journal of Creative Research Thoughts (IJCRT), Volume 11, Issue 2, 2023 — overview of a solar trash collector with floating platform, barriers, and solar-powered control system.
- [2] Muhasin K. M. et al., Solar Based Water Trash Collector, IJCRT, Volume 13, Issue 3, 2025 — discusses design and sustainability of solar trash collectors in rivers and lakes.
- [3] Dr. M. Mohammadha Hussaini et al., Solar-powered debris collector designed for water bodies, IJIREEICE, 2024 — prototype for a solar-powered surface rubbish collector with IoT features.
- [4] Solar Based River Water Garbage Collector, IARJSET — design and analysis of a solar-powered river cleaning machine with automation.
- [5] Solar Powered Water Body Cleaning Robot, IJERT Conference Proceedings, 2023 discusses solar-based robotic cleaning of water surfaces.
- [6] Performance and Analysis of Solar Powered Water Trash Collector Boat - <https://ieeexplore.ieee.org>.
- [7] IoT enabled Solar Powered Water Trash Collector with Conveyor Belt – <https://link.springer.com>.
- [8] Solar Aqua Trash Collector – <https://www.scribd.com>.