

OPTIMIZATION OF A CRANKSHAFT IN CRANK-PIN WEB FILLET REGION FOR IMPROVING FATIGUE LIFE

Mr. Mathapati Nagesh Chandrakant

Department Mechanical engineering, Jaihind College of Engineering, Kuran, Junnar, Pune

[MS] India

Dr. Dhamejani C. L.

Department Mechanical engineering, Jaihind College of Engineering, Kuran, Junnar, Pune

[MS] India

Abstract— a crankshaft is often designed with a fillet radius to improve fatigue life of crankshaft. The fatigue life of crankshaft is depending on the proper fillet radius. This fillet radius is changes than fatigue life is also changes of crankshaft. In most of the time fatigue failure is occur in crank-pin web fillet region. The crankshaft fillet rolling process is one of the commonly adopted methods in engineering to improve fatigue life of the crankshaft. A finite element analysis is implemented to approximate the stress distribution induced in the crankpin fillet region. The modelling of crankshaft is created by Creo-parametric. Finite element analysis is performed to obtain the variation of stress at critical locations and fatigue life of the crank shaft using the ANSYS software and applying the boundary conditions. Existing crankshaft results from finite element analysis is comparing with the experimental result after that boundary conditions are satisfied than only changes in model of crankshaft to improvement in fatigue life. This work in doing for optimization of a crankshaft in crank-pin web fillet region with fatigue life as well as to study a relation between fillet radius/diameter of crankpin to fatigue life. .

Keywords— Crankshaft failure, fatigue, Fatigue life estimation, Finite element analysis.

I. INTRODUCTION

Crankshaft is a large component with a complex geometry in the engine which converts the reciprocating displacement of the piston to a rotary motion. The function of the crankshaft is to convert the convert mechanical energy of the piston being driven back and forth by the pneumatic energy provided by pressure change as a result of the combustion reaction. Crankshafts are high volume production internal combustion engine components and their most commonly used is in an automobile engine. In an engine, the reciprocating motion of the piston is linear and is converted into rotary motion using through the crankshaft. There are many applications of a crankshaft which range from small one cylinder engines to very large multi-cylinder marine crankshafts [1].

Crankshafts in automotive engines can experience a significant number of service cyclic loads. Since fatigue cracks initiated near the fillet lead to one of the primary failure mechanisms of automotive crankshafts, fillet rolling processes have been used to improve the fatigue lives of crankshafts for many years. The fillet rolling process induces compressive residual stresses near the fillet surface. The compressive residual stresses lower the fatigue driving stresses near the fillet surface due to operating loads and consequently increase the fatigue lives of crankshafts.

As a crankshaft is subject to operating loads, the induced stresses at these high stress concentration areas could initiate fatigue cracks and lead to failure. A fillet rolling operation is

one of the commonly used techniques to improve fatigue strength of a crankshaft because this rolling process introduces compressive residual stresses on the contact surface and sub-surface, which will prohibit fatigue cracks to initiate and continuously propagate. The invention regards to minimize stress in fillet region and increases fatigue life of crankshaft using rolling in fillet region of different radius and deep of rolling. The aim of invention is achieve static and dynamic analysis through ANSYS stress value of crankshaft and compare that value to experimental value to improve fatigue life of crank shaft [2].

II. LITERATURE REVIEW

A more amount of work has been done on crankshaft optimization and analysis in fillet of crankshaft using experimental as well as numerical simulation methods and finite element analysis (FEA). But fewer researches have carried on the radius of fillet with FEA. The basic literature available is provided the Mahesh L. Raotole, D. B. Sadaphale, and J. R.Chaudhari presented the Prediction of Fatigue Life of Crank Shaft using S-N Approach [4]. Sanjay B, V M Nandedkar and Surender Kumar Kaundal explain finite element analysis approach for stress analysis of crankshaft under dynamic loading [5]. Paul Spiteria Simon Ho, Yung-Li Lee are explained assessment of bending fatigue limit for crankshaft sections with inclusion of residual stresses [6]. Rajesh M.Metkar, Vivek K.Sunnapwar published Evaluation of FEM based fracture mechanics technique to estimate life of an automotive forged steel crankshaft of a single cylinder diesel engine[7].

III. PROBLEM DEFINITION

Crankshaft is one of the critically loaded components in engine. Fatigue is a source of crankshaft failure. Although, traditionally, crankshaft damages are attributed to wear and lubrication sources, fatigue is responsible for a significant number of crankshaft failure.[8] Fatigue exists when cyclic stresses/deformations occur in an area on a component. The cyclic stresses/ deformations have mainly many origins, in that majorly fluctuating loads, torsion and bending on crank shaft. If number of cylinder are increases this parameter are more affected for the crankshaft fatigue failure. In Fig.1 fatigue failure occur in fillet region of crankshaft.



Fig. 1 Final failure On fillet of crankshaft

IV. DESIGN CALCULATION

For the project work using paggio vehicle of engine model G 400 WG III. The technical specification of engine is in Table I.

TABLE I
The Technical Specification of Engine

Capacity	395 cc
Number of Cylinders	1
Bore x Stroke	86 x 68 mm
Compression Ratio	09:01
Maximum Power	8.1hp @ 3600 rpm
Maximum Torque	16.7 Nm @ 2200 rpm
Maximum gas pressure	25 bar
Fillet Radius	3.5

Force on the Piston $F_p = \text{Area of the bore} \times \text{Max. Combustion pressure} = \pi \times D^2 \times P_{\text{max}} = 14.52 \text{ KN}$

In order to find the thrust in the connecting rod (FQ), We should first find out the angle of inclination of the Connecting rod with the line of stroke (i.e. angle θ).

We know that

$$\sin \theta = (\sin \theta / (L/R)) = \sin 35^\circ / 4$$

Which implies $\theta = 8.24^\circ$

We know that thrust in the connecting rod

$$FQ = FP / \cos \theta$$

From this we have,

Thrust on the connecting rod $FQ = 14.67 \text{ KN}$

Thrust on the crank shaft can be split into Tangential component and the radial component.

1) Tangential force on the crank shaft, $F_T = FQ \sin(\theta + \theta) = 10.05 \text{ KN}$

2) Radial force on the crank shaft, $F_R = FQ \cos(\theta + \theta) = 10.68 \text{ KN}$

Reactions at bearings (1 & 2) due to tangential force is given by,

$$H_{T1} = H_{T2} = (F_T \times b_1) / b = 5.02 \text{ KN} \text{ (Since } b_1 = b_2 = b/2)$$

Similarly, Reactions at bearings (1 & 2) due to radial force is given by,

$$H_{R1} = H_{R2} = (F_R \times b_1) / b = 5.34 \text{ KN} \text{ (Since } b_1 = b_2 = b/2)$$

V. FEA APPROCH

Finite element analysis of crankshaft is done by geometry generation using creo-Parametri software and analysis is using through the ANSYS 14.5 WORKBENCH software. using proper type of loading and boundary condition are very important in finite element analysis.

A. Generation of Geometry of Crankshaft using Creo-Parametric

From the measuring all parameter of actual crankshaft of Paggio vehicle of engine model G 400 WG III to the drawing, the dimensions of crankshaft, solid model is generated using Creo-Parametric software. Fig.2 shows the solid model of the forged steel crankshaft from actual dimension. After completion of solid model save as this part as IGES for Exporting into ANSYS WORKBENCH Environment.

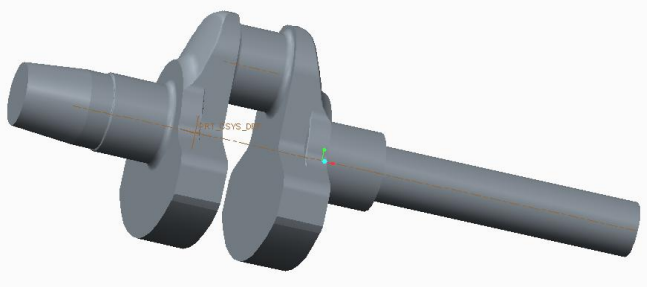

Fig.2 Generated Geometry of Crankshaft

B. Engineering Data

In the engineering data add the basic property of crankshaft.

Material Details

Material Type: - Forged Steel

Designation: - 42CrMo4

Yield strength (MPa):- 680

Ultimate tensile strength (MPa):- 850

Elongation (%):-13

Poisson ratio:-0.3

C. Mesh Generation

Import IGES format model in ANSYS WORKBENCH simulation module. Quadratic tetrahedral elements are used to mesh the crankshaft finite element geometry.

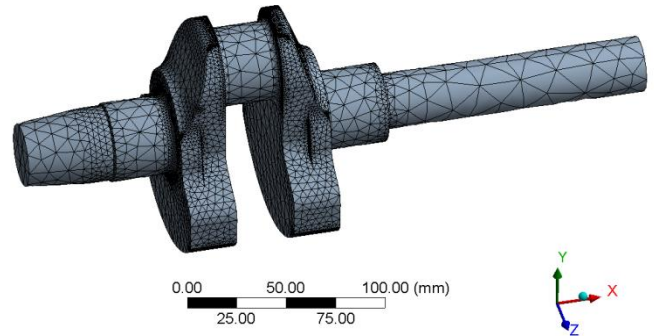

Fig.3 Meshed Model of Crankshaft

Tetrahedral elements are used for meshing the imported complex geometries to the ANSYS WORKBENCH software. In Fig.3 shows the meshed model of crankshaft of 17789 number of nodes and 9615 number of elements.

D. Boundary conditions

Boundary conditions are play the important role in finite element analysis. The bearing support are fixed and apply tangential and radial force on crankshaft. Fig.4 shows the apply remote displacement for bearing support fixed and apply forces on crankpin.

A: boundary condition for actual condition
Static Structural
Time: 1, s
14-06-2015 12:30
A Fixed Support
B Force: 14607 N

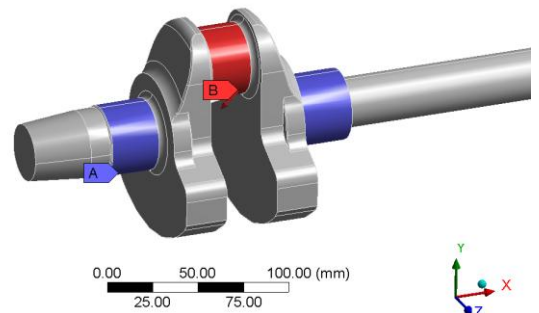

Fig.4 Boundary conditions for crankshaft

E. Von Misses Stress

After compilation boundary condition find out the critical point (maximum stress) on crankshaft to know the where crack is occurring. Fig.5 shows the von misses stress on the crankshaft. From figure maximum stress in on the fillet of crankshaft.

C: von mises stress
Equivalent Stress
Type: Equivalent (von-Mises) Stress
Unit: MPa
Time: 1
14-06-2015 12:48

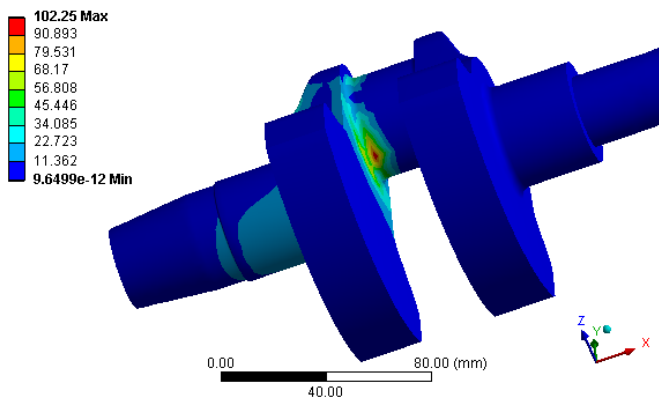

Fig.5 Von Misses Stress

F. Fatigue life

Using fatigue tool obtain fatigue life of crankshaft and obtain same for the various radius of fillet in crankpin region. Fig.6 shows the fatigue life of crankshaft. From the figure the minimum fatigue life is obtained on the maximum Von mises stress occur means the fatigue crack starts from that region. To comparing fatigue life of different fillet radius in crankpin following the same method to obtain fatigue life. In the geometry only changes the fillet radius and other boundary conditions are same.

C: fatigue life for experiment condition
Life
Type: Life
Time: 0
14-06-2015 12:10

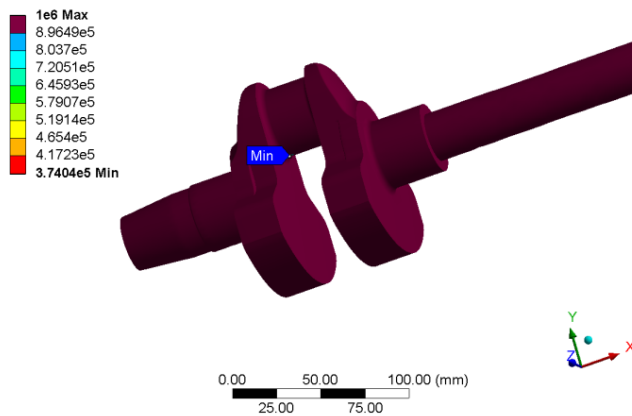

Fig.6 Fatigue life of crankshaft

VI. EXPERIMENTAL SET-UP

To obtained fatigue life of crankshaft experimentally using through Instronhydropuls-actuator. As per the requirement the fixture designed and manufacturing according to the conditions. First create a drawing of set-up and then manufacturing setup. In the set-up include one rod is using to applied load on crankshaft, second is two clamping one is used to fix the crankpin and second is used to fix the bearing support and last one is plate to support and fix all components. Fig.7 shows the model of experimental set-up using through the creo-Parametric.

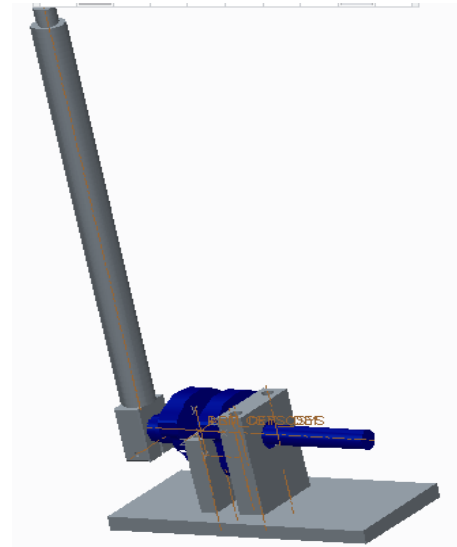

Fig.7 Model of Experimental Set-up

To calculate fatigue life experimentally the force is applied on the tapped region in positive as well as negative vertical directions. The compression and tensile force apply on the tapped region. To the testing machine input is force apply on the crankshaft and output from the machine is number of cycles and lodes on crankshaft. Applied the cyclic loading on crankshaft. In Fig.8 experimental set-up on the testing machine. After all set-up to start the applying the force on forded steel crankshaft[6].

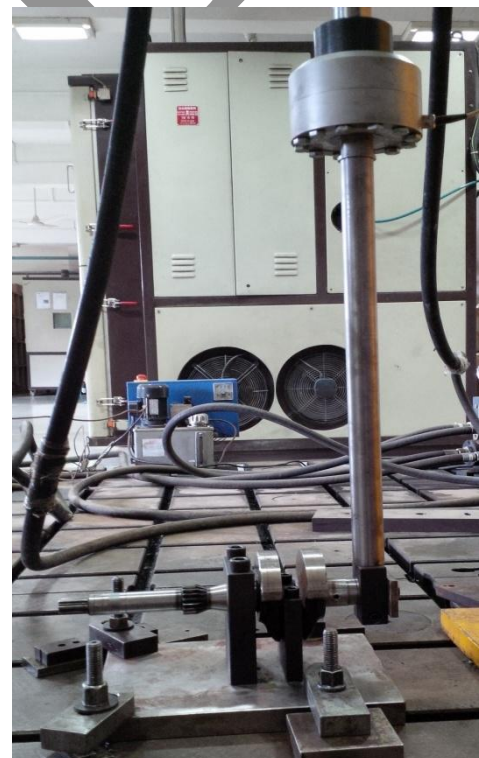

Fig.8 Experimental Set-up

VII. RESULTS

The results are obtained using the FEA and experimentally are in the table 2. In table 2 the fatigue life of existing forged crankshaft.

TABLE II
Number Of Cycles To Failure Of Existing Crankshaft

Number of cycles to failure	
FEA	Experimentally
3.7404×100000	3.5648×100000

Above results shows that FEA results conformal matches with the experimental results so all boundary conditions of are satisfied with experimentally so we can say that FEA is good software to reduce time consuming experimental work. The crack start from the where the maximum von misses stress is formed. Therefore, fatigue life of forged steel crankshaft obtained for different fillet radius r to crank pin diameter d ratio and it is shown below. It is seen from the table, fatigue life of crankshaft increases with the increase in r/d ratio. Similarly, the calculation for $r/d = 0.03, 0.06, 0.08$ and 0.1 and software calculation results as given in the following Table3.

TABLE III
Number Of Cycles To Failure For Different r/d Ratio

Sr. No.	Fillet Radius	r/d Ratio	Number of Cycles to Failure
1	1.5	0.03	2.4951×100000
2	2.5	0.06	3.1685×100000
3	3.5	0.08	3.7404×100000
4	4	0.1	5.7842×100000
5	4.5	0.1125	8.1389×100000

To obtained above results only changes in the radius of fillet of crankpin all other parameters and boundary conditions are same. Results are obtained from the ANSYS WORKBENCH 14.5 using fatigue tool.

VIII. CONCLUSIONS

In this paper finite element analysis and experimental method are use to calculating number of cycles to failure of crankshaft.

The maximum stress and deformation appears at the centre of crankpin fillet between the crankshaft journal and crank cheeks, and near the central point journal. The edge of main journal is maximum stress area in the crankshaft.

FEA analysis using ANSYS WORKBENCH FROM fatigue tool is very efficient and simple method for achieving fatigue at different loading condition according to force applied to the crankshaft. The using experimental method for calculating fatigue life is very costly and to take a long time. The use of numerical method such as Finite Element Method now a day's commonly used to gives detail information about various structure or components.

The r/d ratio is increases than Von misses stress are decreases as well as number of cycles to failure in increases.

ACKNOWLEDGMENT

I take this opportunity to thank all those who have contributed in successful completion of this paper. I wish to express my thanks to, Dr. Dhamejani C. L. Principal, JCOE, Kuran, and Prof. Galhe D. S. Project Co-coordinator (Mech. Design Eng.) for their support and the help extended. Finally, I am thankful to all those who extended their help directly or indirectly in preparation of this report.

References

- [1] George E. Dieter, Mechanical Metallurgy, 3rd Edition, McGraw Hill Education, 2013, Pp. 375 – 431
- [2] Warren C. Young Richard G. Budynas, Roark's Formulas For Stress And Strain, Seventh Edition New York Chicago San Francisco Lisbon London, Pp. 771 - 799, 2002.
- [3] Walter D. Pilkey Deborah F. Pilkey, Peterson's Stress Concentration Factors, Third Edition, John Wiley & Sons, Inc., Pp. 422 – 427, 2007.
- [4] Mahesh L. Raotole, Prof. D. B. Sadaphale, Prof. J. R. Chaudhari, "Prediction of Fatigue Life of Crank Shaft using S-N Approach", International Journal of Emerging Technology and Advanced Engineering, vol.3, Pp. 427-454, 2013.
- [5] Sanjay B, V M Nandedkar and Surender Kumar Kaundal explains "finite element analysis approach for stress analysis of crankshaft under dynamic loading", INTERNATIONAL Journal of Scientific & Engineering Reserch, vol 4, Pp 1-6, 2013.
- [6] Simon Ho, Yung-Li Lee, Hong-Tae Kang, Cheng J. Wang, "Optimization Of A Crankshaft Rolling Process For Durability", International Journal Of Fatigue, International Journal Of Fatigue 31, Pp. 799–808, 2009.
- [7] Rajesh M. Metkar, Vivek K. Sunnapwarb, Subhash Deo Hiwasec, Vidya Sagar Ankid, Mahendra Dumpa, "Evaluation Of Fem Based Fracture Mechanics Technique To Estimate Life Of An Automotive Forged Steel Crankshaft Of A Single Cylinder Diesel Engine", Procedia Engineering, Procedia Engineering 51, Pp. 567 – 572, 2013.
- [8] M. Fonte, M. De Freitas, "Marine Main Engine Crankshaft Failure Analysis: A Case Study", Engineering Failure Analysis 16, Pp. 1940 – 1947, 2009.
- [9] Farzin H. Montazersadgh And Ali Fatemi, "Dynamic Load And Stress Analysis Of A Crankshaft", Sae International, 2007-01-0258
- [10] K.S. Choi, J. Pan, "Effects Of Pressure-Sensitive Yielding On Stress Distributions In Crankshaft Sections Under Fillet Rolling And Bending Fatigue Tests", International Journal Of Fatigue 31 Pp. 1588–1597, 2009.
- [11] Jing Zhao, Shijie Wang, "Analysis For Fatigue Failure Causes On A Large-Scale Reciprocating Compressor Vibration By Torsional Vibration", Procedia Engineering, Procedia Engineering 74, Pp. 170 – 174, 2014.
- [12] W.Y. Chien, J. Pan, D. Close, S. Hob, "Fatigue" Analysis Of Crankshaft Sections Under Bending With Consideration Of Residual Stresses", International Journal Of Fatigue 27 Pp. 1–19, 2005.
- [13] Paul Spiteri, Simon Ho And Yung-Li Lee, "Assessment Of Bending Fatigue Limit For Crankshaft Sections With Inclusion Of Residual Stresses", International Journal Of Fatigue, 29 Pp. 318–329, 2008
- [14] Xuanyang Leia, Guicai Zhanga, Song Xigengb, Jin Chena, Guangming Dong, "Simulation On The Motion Of Crankshaft With Crack In Crankpin-Web Fillet Region" Journal Of Sound And Vibration, 295 Pp. 890–905, 2006.
- [15] K.S. Choi, J. Pan, "Simulations Of Stress Distributions In Crankshaft Sections Under Fillet Rolling And Bending Fatigue Tests", International Journal Of Fatigue 31 (2009), Pp. 544–557
- [16] M. Fonte, M. De Freitas, Marine Main Engine Crankshaft Failure Analysis: "A Case Study. Engineering Failure Analysis, Engineering Failure Analysis" 16 Pp. 1940–1947, 2009.