

## **WIRELESS SENSOR NODE FOR DATA COLLECTION IN RESTRICTED ZONE**

R.C.Mahajan,  
Zeal College of Engineering and Research, Pune  
Mrunali D.Jadhav,  
Zeal College of Engineering and Research, Pune

### **Abstract**

**The wireless sensor networks combine sensing, computation and communication into a single tiny device. The application of wireless sensor network technology is to monitor remote environments, collect data from particular area. The wireless sensor network architecture includes hardware platform which contain metallic skeleton with attached solar panels .This mainly contains temperature sensor, humidity sensor, smoke detector, sound detector, PIR etc The main contributions of this work are (1) a general architecture that meets efficiency and flexibility requirements of wireless sensor networks, (2) an implementation of the architecture using current microcontroller and wireless transmitter. The environmental data collection application is characterized by nodes continually sensing and transmitting data back to a set of base stations that store the data. These networks generally require very low data rates and extremely long lifetimes.**

### **INTRODUCTION**

There are two opposite approaches in the technology for collecting environmental data. The first can be realized by autonomous recorders of physical quantities (loggers): devices are installed at a required point to scan parameters at a required frequency, keeping them in a local storage. In order to obtain data from such device, a direct contact has to be established with it. This is inconvenient, if the device is installed in a remote place (for example, trees, wells etc.), and can be time consuming, if several dozen devices are installed at the studied area. The second approach is to use a fixed wire or wireless data collection network, capable of transmitting large amounts of data in real time. The disadvantage of this approach is high energy consumption, the need for laying cables or radio paths, regular maintenance of units, and the vulnerability of the entire network in the event of failure of communication channels. All this leads to a substantial increase in the cost and time of deployment.

There are two types of data transmission in wireless sensor network, these are – direct transmission and multi-

hop data transmission. In direct transmission data are send directly to the sink where as multi-hop transmission data send via no of intermediate nodes lies between source node and base station. In sensor network the flow of data is very important aspect because each data packet contains the event which may be very important for some application.

Sensor nodes are small embedded devices which are mainly able to perform simple computations and to send/receive data. Their typical usage is to gather information about their environment via sensors, to potentially pre-process these data, and to finally transmit them. An autonomous set of such nodes is called a wireless sensor network (WSN) [1]. Because of cost and energy constraints, only one node is generally able to transmit data from the sensor network to the “outside world” by means of a longer-range connection (e.g., GPRS). This node is called a sink since it acts as such with regards to the data stream coming from the network.

In this technology, which is a rapidly deployable wireless network consisting of a set of almost autonomous recorders (wireless sensor network, WSN).The nodes of the network do not require maintenance and replacement of power supply for months, even years, but at the same time collecting data from all nodes can be performed remotely from different places and at any time.

The most important characteristics of the environmental monitoring are long lifetime, precise synchronization, low data rates and relatively static topologies. Once the network is configured, node periodically samples its sensors and transmits its data to the base station. For many scenarios, the interval between these transmissions can be on the order of minutes. Typical reporting periods are expected to be between 1 and 15 minutes; while it is possible for networks to have significantly higher reporting rates. The typical environment parameters being monitored, such as temperature, smoke, sound and humidity.

### **REVIEW OF LITERATURE**

In 2010 K.Ramanan and E.Baburaj did the survey on data gathering algorithms for wireless sensor network. In this paper they have explored general network lifetime in wireless sensor networks and made an extensive study to categorize available data gathering techniques and analyze

possible network lifetime on them. The main constraint of sensor nodes is their very low finite battery energy, which limits the lifetime and the quality of the network. The aim is efficient transmission of all the data to the base station so that the lifetime of the network is maximized in terms of rounds, where a round is defined as the process of gathering all the data from sensor nodes to the base station, regardless of how much time it takes. Existing data gathering protocol can be classified in to different categories based on the network structure and protocol operation based on routing protocols that aim at power-saving and prolonging network lifetime are intensively studied in research community.

In June 2012, Rudranath Mitra, Tauseef Khan did the survey of secure and reliable data transmission in wireless sensor network. Here they discussed how the authentication and confidentiality maintained during data transmission because without this two parameter data transmission cannot be reliable; also they discussed how the missing packets can be detected during transmission by some efficient methods. In this paper they discussed various ways to make the data transmission secure and efficient; also they discussed some mechanism and protocol used in secure data transmission.

Martin[2], in this paper, they focus on the particularities of environmental monitoring through their experience with Sensor Scope. Environmental monitoring, in particular, is very demanding due to harsh outdoor conditions that may greatly impact hardware performance. In Sensor Scope, they have been faced with many challenges, and they describe here, how they coped with them. As a case in point, they have already been able to deploy several networks, some of them in very harsh conditions, and they present results from such a deployment, which took place on a high mountain pass in Switzerland. Sensor Scope stations are composed of an aluminum skeleton equipped with a solar panel, seven external sensors, and an hermetic box, enclosing electronic parts.

Feng Wang, in this paper presented a survey on recent advances in this research area. They have first highlight the special features of sensor data collection in WSNs, by comparing with both wired sensor data collection network and other WSN applications. With these features in mind, they discussed the issues and prior solutions on the utilizations of WSNs for sensor data collection. In each stage, they discuss the issues and challenges, followed by a review and comparison of the previously proposed approaches and solutions, striving to identify the research and development trend behind them. In addition, they further discuss the correlations among the three stages and outline possible directions for the future research of the networked wireless sensor data collection.

Andreev in 2012 proposed the technology for collecting low-frequency and event detecting in high-frequency environmental data streams using wireless sensor networks,

a developed set of sensors for different sampling rates, detectors for high-frequency events, and software to convert, store and visualize the data. This paper presents a compromise technology, which is a rapidly deployable wireless network consisting of a set of almost autonomous recorders (wireless sensor network, WSN). The basis of this technology is weather-sealed intellectual sensors (motes) with a built-in microprocessor, connected by a digital radio channel with a decentralized peer to peer (P2P) communication protocol (IEEE 802.15.4 ZigBee), tolerant to faults of individual transponders and equipped with software, optimized for data collection and event detection directly on the network nodes. Such network can be used for rapid deployment in remote places, followed by collecting data by using radio without having to crawl to all sites.

Suchita in 2013 shows WSNs with static sink node and WSNs with mobile sink node and mainly focused on data collection method which make communication feasible between sink node and sensor nodes. It also shows different types of wireless sensor networks architectures used for data collection purpose; shows the preliminaries in wireless sensor network and data collection with sink nodes. Many studies show that the mobile sink node collect data from the sensors deployed in the field. Mobile sink node collect the data directly using one hop transmission from the sensor or some time using multi-hop transmission. In some cases cluster technique is used for the data collection from sensor. In this technique the mobile sink node collects data from the cluster head and stored data on the Database (Base station). Data collected from sensor is stored on the gateways then mobile sink gets that data and stored on the Database (Base station) this is again one technique for data collection process.

A. Rajeswari in 2014 studied that in wireless Sensor Networks, sending large amount of data directly to the sink node may cause several problems. The approximate data collection is the suitable method for long term data collection in wireless sensor networks with bounded bandwidth. The number of application in WSNs needs to collect data approximately and efficiently due to constraints in energy budget and communication bandwidth. This technique is called ADC (Approximate Data Collection). In order to increase energy efficiency and extend the network lifetime, New and efficient power saving algorithms are developed. The Approximate Data Collection scheme should be scalable. This technique is more efficient to physical environmental changes and reduces message retransmission.

Somov in 2014 proposed prototype is characterized by temperature and humidity sensors with quick response time, high sensitivity, and low power consumption. Besides, sensors can be deposited directly onboard ensuring a small form factor facilitating their true ubiquitous deployment. The proposed solution can be used for environmental moni-

toring in difficult to access areas and ensure quick data delivery to a user over the wireless network. The goal of this work is to embed a state-of-the-art temperature and humidity film sensors in a wireless sensor node and use it in the emergency applications, e.g. fire detection and unauthorized entry.

In 2015 Koppala Guravaia introduces a new mechanism for data collection and routing based on River Formation Dynamics. The proposed algorithm is termed as RFDMP: River Formation Dynamics based Multi-hop Routing Protocol. This algorithm is explained and implemented using MATLAB. The performance results are compared with LEACH and MODLEACH. The comparison reveals that the proposed algorithm performs better than LEACH and MODLEACH. RFDMP, a multi-hop routing protocol, is proposed for data collection in WSN.

### PROPOSED RESEARCH WORK

The architecture of the sensor node, shown in Fig. 1, includes four main blocks: sensing processing, communication, and power management. In the proposed research work, we are developing one wireless sensor node to collect and transmit the data in the restricted area. This data mainly contains temperature, humidity, smoke, and PIR(motions)etc. When we will scatter that node in the restricted area then it automatically opens and sensors connected to it collect the required information within that area and send this information through the wireless transmitter to the antenna.

Sensing units are usually composed of two sub-units: sensors and analogue to digital converters (ADCs). The analogue signals produced by the sensors are converted to digital signals by the ADC, and then fed into the processing unit. The processing unit is generally associated with a small storage unit and it can manage the procedures that make the sensor node collaborate with the other nodes to carry out the assigned sensing tasks. A transceiver unit connects the node to the network. One of the most important components of a sensor node is the power unit. Power units can be supported by a power scavenging unit such as solar cells. The other subunits, of the node are application dependent. The sensing unit detect potential fire or unauthorized entry. The sensors advantages over off-the-shelf components are quick response time and high sensitivity allowing, for instance, to immediately detect a person entry in that area.

The main duties of the microcontroller are to execute the communication protocols, control the radio, interact with sensors and perform data processing. In general, sensor nodes only require small amounts of storage and program memory. Data is only stored long enough for it to be analyzed and then transmitted through the network to the

base station. The microprocessor as a number of functions including: Managing data collection from the sensors, performing power management functions, interfacing the sensor data to the physical radio layer, managing the radio network protocol.

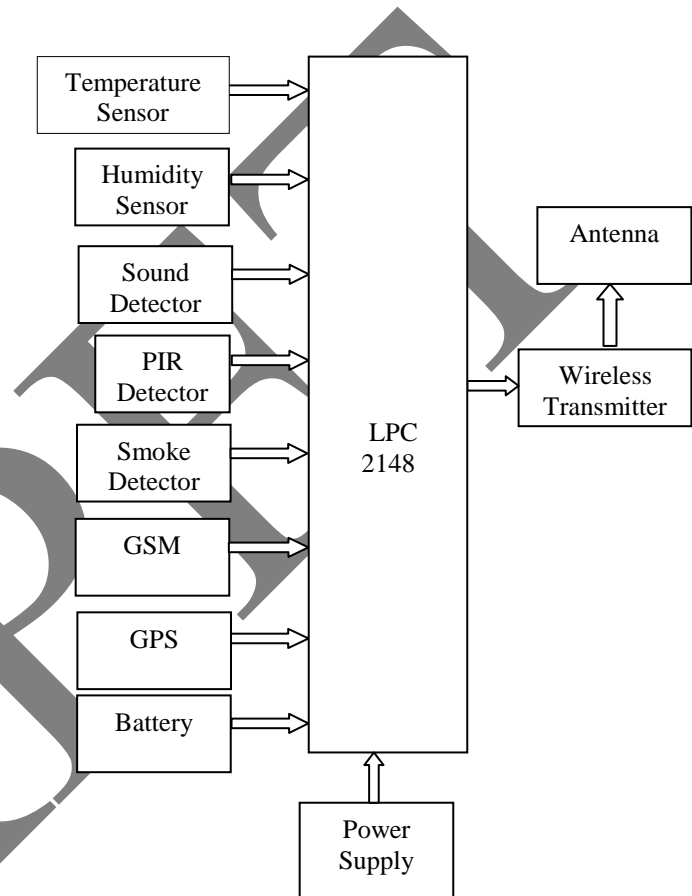

**Figure 1 Block diagram of proposed method**

A key aspect of any wireless sensing node is to minimize the power consumed by the system. The power consumption of a sensor is equally dependent on the amount of time it takes to read the sensor as it is to the current consumption. The sensor nodes will remain dormant a majority of the time; they will only wake to transmit or receive data. The primary limiting factor for the lifetime of a sensor network is the energy supply. The node must be designed to manage its local supply of energy in order to maximize total network lifetime. In most application scenarios, a majority of the nodes will have to be self powered. They will either have to contain enough stored energy to last for years, or they will have to be able to scavenge energy from the environment through devices, such as solar cells etc. Usually, the radio subsystem requires the largest amount of power. Therefore, data is sent over the radio network only when it is

required. An algorithm is to be loaded into the node to determine when to send data based on the sensed event. Furthermore, it is important to minimize the power consumed by the sensor itself. Therefore, the hardware should be designed to allow the microprocessor to judiciously control power to the radio, sensor, and sensor signal conditioner.

**Power Supply**

LPC218 works on 3.3V power supply LM117 can be used for generating 3.3V supply. However basic peripherals like LCD,ULN2003(motor driver IC) etc. works on 5V.So AC mains supply is converted into 5V using below mentioned circuit after that LM117 is used to convert 5V to 3.3V. Regulator IC 7805 is used to provide fix 5V dc supply.

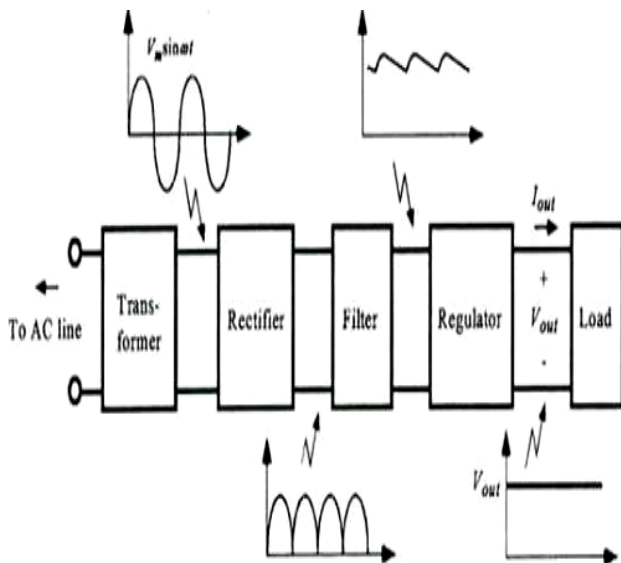

**Figure 2 Components of a typical linear power system**

**ARM 7TDMI**

The ARM7TDMI is a general purpose 32-bit microprocessor, which offers high performance and very low power consumption. The ARM architecture is based on Reduced Instruction Set Computer principles and the instruction set and related decode mechanism are much simpler than those of micro Programmed Complex Instruction Set Computers.

- T:** Thumb, 16-bit compressed instruction set
- D:** on-chip Debug support, enabling the processor to halt in response to a debug request
- M:** enhanced Multiplier, yield a full 64-bit result, high performance
- I:** Embedded ICE hardware

**Features of LPC2148**

16-bit/32-bit ARM7TDMI-S microcontroller in a tiny LQFP64 package.

8 kB to 40 kB of on-chip static RAM and 32 kB to 512 kB of on-chip flash memory. 128-bit wide interface/accelerator enables high-speed 60 MHz operation.

- One or two (LPC2141/42 vs. LPC2144/46/48) 10-bit ADCs provide a total of 6/14 analog inputs, with conversion times as low as 2.44 μs per channel.

Single 10-bit DAC provides variable analog output (LPC2142/44/46/48 only).

Low power Real-Time Clock (RTC) with independent power and 32 kHz clock input.

- On-chip integrated oscillator operates with an external crystal from 1 MHz to 25 MHz.
- Single power supply chip with POR and BOD circuits:
- CPU operating voltage range of 3.0 V to 3.6 V (3.3 V ± 10 %) with 5 V tolerant I/O pads.

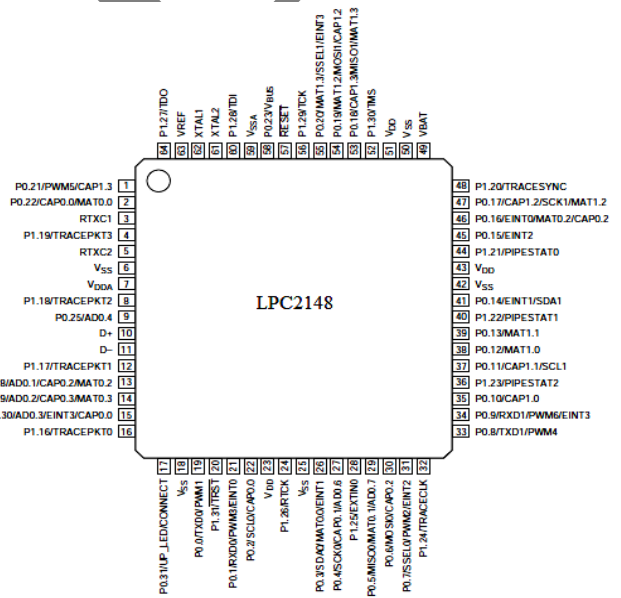

**Figure 3 Pin out of LPC2148**

Temperature sensor (LM35)

The LM35 series are precision integrated-circuit temperature sensors, whose output voltage is linearly proportional to the Celsius (Centigrade) temperature. The LM35 thus has an advantage over linear temperature sensors calibrated in ° Kelvin, as the user is not required to subtract a

large constant voltage from its output to obtain convenient Centigrade scaling.

#### Features of LM35

- Calibrated directly in ° Celsius (Centigrade)
- Linear + 10.0 mV/°C scale factor
- 0.5°C accuracy guarantee able (at +25°C)
- Rated for full -55° to +150°C range
- Low cost due to wafer-level trimming
- Operates from 4 to 30 volts
- Less than 60 μA current drain
- Low impedance output, 0.1 W for 1 mA load

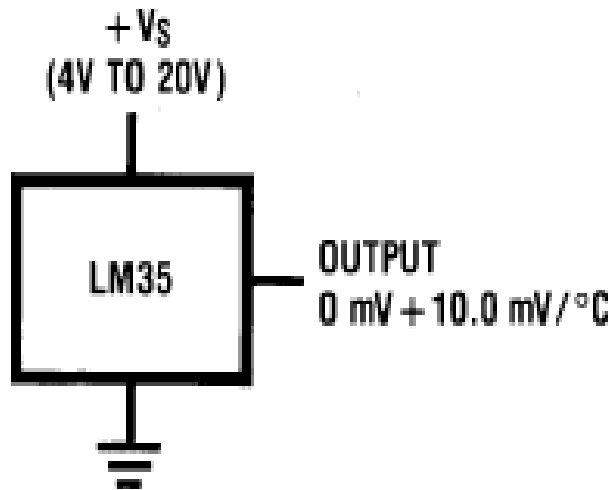

Figure 4 Basic Centigrade Temperature Sensor

#### HUMIDITY SENSOR

Humidity sensor senses, measures and reports the relative humidity in the air. It therefore measures both moisture and air temperature. Relative humidity is the ratio of actual moisture in the air to the highest amount of moisture that can be held at that air temperature. Humidity sensor can be used as a monitoring and preventive measure in greenhouses and can be used in meteorology stations to report and predict weather.

#### SOUND DETECTOR

Sound detector can be used for security purpose. When any person enters in the area, some sort of sound is generated. It may be voice or any other sort of sound.

#### PIR (PASSIVE INFRARED SENSOR)

A PIR is an electronic sensor that measures infrared (IR) light radiating from objects in its field of view. A PIR based motion detector is used to sense movement of people, animals, or other objects.

#### SMOKE DETECTOR

Smoke detector is a device that senses smoke, typically as an indicator of fire.

- High sensitivity to LPG, Propane and Hydrogen, Methane and other combustible steam
- It is with low cost and suitable for different application.
- It has high sensitivity to fast burning, flaming fires that produce small smoke particles.
- When the target combustible gas exist, the sensor's conductivity is more higher along with the gas concentration rising.

#### GPS (GLOBAL POSITIONING SYSTEM)

The Global Positioning System (GPS) is a space-based navigation system that provides location and time information in all weather conditions, anywhere on or near the Earth where there is an unobstructed line of sight to four or more GPS satellites. The system provides critical capabilities to military, civil, and commercial users around the world. GPS satellites continuously transmit their current time and position. A GPS receiver monitors multiple satellites and solves equations to determine the exact position of the receiver and its deviation from true time. At a minimum, four satellites must be in view of the receiver for it to compute four unknown quantities (three position coordinates and clock deviation from satellite time).

#### GSM (GLOBAL SYSTEM FOR MOBILE COMMUNICATION)

GSM means the global system for mobile communication. It can be used for sending message to the user. Now it is important to learn how GSM networks work and what the architecture of the GSM network is. GSM networks consist of three major systems: SS, which is known to be The Switching System; BSS, which is also called The Base Station; and the Operation and Support System for GSM networks

#### LCD (LIQUID CRYSTAL DISPLAY)

LCD display is used to display the data which sensed by different sensors. 16 x 2 LCD means it can display 16 characters per line and there are 2 such lines.

**Features of LCD**

- Flat panel display that uses the light modulating properties of liquid crystals (LCs)
- The 2x16 character LCD interface card with supports both modes 4-bit and 8-bit interface
- Facility to adjust contrast through trim pot.
- In 4-bit interface 7 lines needed to create 4-bit interface
- 4 data bits (D0 – D3), three control lines, address bit (RS), read/write bit (R/W) and control signal (E).

**LCD1**  
LM016L

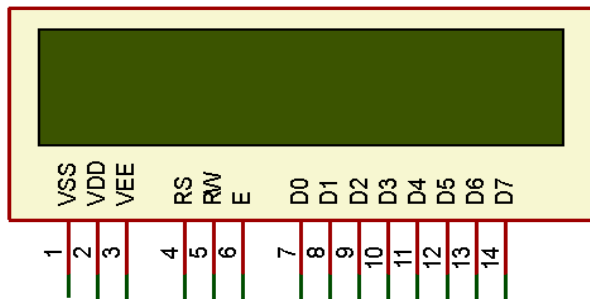

**Figure 5 Pin diagram of 16x2 LCD**

**ADVANTAGES**

There are a number of advantages of wireless sensor networks.

The benefits include:

- Simple installation and maintenance. The network is easy to install, it doesn't require any additional communication. Downloading of data does not require direct contact with each node, which is important for inaccessible locations.
- Mobility. Network configuration can change rapidly without additional effort. Software update for each sensor can be loaded on the same radio channels as the data collection.
- Scalability. The network may include hundreds or thousands of nodes. New nodes can be added dynamically without having to reconfigure the network.
- Separate "dense" network, in which data is exchanged via ZigBee or Bluetooth.
- Minimum Power consumption
- Ability to withstand in unfavorable environmental conditions
- Ease of use

**APPLICATIONS**

➤ **Security monitoring**

These networks are composed of nodes that are placed at fixed locations throughout an environment that continually monitor one or more sensors to detect an anomaly.

➤ **The tracking of a tagged object**

There are many situations where one would like to track the location of valuable assets or personnel. With wireless sensor networks, objects can be tracked by simply tagging them with a small sensor node. The sensor node will be tracked as it moves through a field of sensor nodes that are deployed in the environment at known locations.

➤ **Security and surveillance**

Security and detection are the important application of wireless sensor networks. Sensor node with motion capabilities may be deployed at the borders to detect the intruder crossing the line of control. Hence surveillance of regions, assets, perimeter, borders and cleared areas can be Efficiently done by deploying wireless sensor networks.

➤ **Environmental monitoring**

The term Environmental Sensor Networks have evolved to cover many applications of WSNs to earth science research including sensing volcanoes, oceans, glaciers, forests etc. Some examples of major areas listed below.

• **Air quality/Air pollution monitoring**

Wireless sensor network have been deployed in several cities to monitor the concentration of dangerous or harmful gases for human.

• **Forest fire detection**

To detect the fire in forest, a network of Sensor Nodes can be installed. With the help of such type of wireless sensor networks we can take early action to protect forest.

• **Climate monitoring**

The climate change of the world nowadays have brought many effects such as the breaking of sea ice, increasing in sea water level, heat wave, glacier melting, temperature warming and many more. Thus using WSNs we can monitor and can try to minimize these harms.

➤ **Greenhouse monitoring**

Now a days, we witness more and more electronic application in an average household. Therefore, great commercial opportunities exist for home automation and smart home/office environment cooling, heating and humidity control. These parameters can be monitored and controlled by WSNs.

### ACKNOWLEDGMENTS

We are thankful to IJRPET Journal for the support to develop this document. We express our sincere gratitude to the senior members of Faculty, Department of Electronics and Telecommunication for extending their valuable time and guidance for the completion of this paper.

### REFERENCES

- [1] F. Akyildiz, W. Su, Y. Sankarasubramaniam, and E. Cayirci, "Wireless Sensor Networks: A Survey", *Computer Networks*, 38, pp. 393-422, 2002
- [2] uillermo Barrenetxea, Francois Ingelrest, Gunnar Schaefer, and Martin Vetterli "Wireless Sensor Networks for Environmental Monitoring: The SensorScope Experience"
- [3] Yu Wang, Hongyi Wu, and Nian-Feng Tzeng, "Energy-efficient Data Transmission in Wireless Sensor Networks", in *Center for Advanced Computer Studies University of Louisiana*
- [4] Prabhudutta mohanty, sangram panigrahi, nityananda sarma and Siddhartha sankar satapathy, "Security issues in wireless sensor network data Gathering protocols: a survey", *Journal of Theoretical and Applied Information Technology* © 2005 – 2010
- [5] Jasmine Norman ; J.Paulraj Joseph ; P.Prapoorna Roja, "A Faster Routing Scheme for Stationary Wireless Sensor Networks - A Hybrid Approach", 2010 *International Journal of Ad Hoc, Sensor & Ubiquitous Computing*
- [6] A. A. Poyda<sup>1</sup>, M. N. Zhizhin<sup>2</sup>, and A. V. Andreev "Wireless sensor networks for environmental data collection and events detection" *RUSSIAN JOURNAL OF EARTH SCIENCES*, VOL.12, 2012
- [7] Koppala Guravaiah and R. Leela Velusamy, "RFDMRP: River Formation Dynamics based Multi-Hop Routing Protocol for Data Collection in Wireless Sensor Networks" Eleventh International Multi-Conference on Information Processing-2015 (IMCIP-2015) Department of Computer Science &

Engineering, National Institute of Technology, Tiruchirappalli, India

- [8] A. Somova ,V. Lebedevb EUROSENSORS 2014,the XXVIII edition of the conference series "Wireless Sensor Node with Ultrasensitive Film Sensors for Emergency Applications"
- [9] Suchita R.Wankhade<sup>1</sup> and Nekita A.Chavhan "A Review OData Collection Method With Sink Node In Wireless Sensor Network" *International Journal of Distributed and Parallel Systems (IJDPS)* Vol.4, No.1, January 2013

### Biographies

**MRUNALI D. JADHAV** received the B.E. degree in Electronics and Telecommunication Engineering from the Savitribai Phule University of Pune, Indapur, Maharashtra, in 2014, Appearing for the M.E. degree in Vlsi and Embedded System Engineering from the Savitribai Phule University of Pune, Pune, Maharashtra, in 2016. Miss Mrunali D.Jadhav may be reached at [mrunal510@gmail.com](mailto:mrunal510@gmail.com)