

## VISUALIZATION, MODELING, AND GRAPHICS FOR ENGINEERING DESIGN

Gapporov Behzod Ne'matillayevich

Senior lecturer in Engineering and Computer Graphics

Jizzakh Polytechnic Institute

**ABSTRACT:** The process engineering design (design) begins with visualization, i.e., reviewing the problem and possible solutions. Then, sketching leads to the preparation of the initial idea. Next step is preparation of geometric models, which are used for a variety of engineering analysis and, finally, creating detailed drawings and/or 3D models, which are used for the production process. Visualization, sketching, modelling and preparation of technical documentation are ways in which engineers and technologists communicate in creating new products and structures in the modern technical world.

**KEYWORDS:** illustrations correspondence, freehand drawing, 3D models, 3D demonstrating, correspondence process.

Brain forms and deciphers visual data and controls muscles that hold a pencil (Figure 1). As a 3D object, a drawing that is shaped on the paper can be seen and serve to make associations and center the picture in the brain of the client. Along these lines, making a circle move structure between the brain, the level/pencils and drawing, which permits understand the possibility of 3D objects. At the end of the day, the picture in the psyche can be framed without the guide of a genuine item. Presently sketch a considerably more significant job, since the genuine subject isn't in the field of view (or maybe even the thought) and the sketch turns into the sole record of the item. The eyes and the psyche, seeing the sketch, can start alteration and advancement office, new drawings can be made, and the entire cycle can be beginning once more. This is just perception cycle.

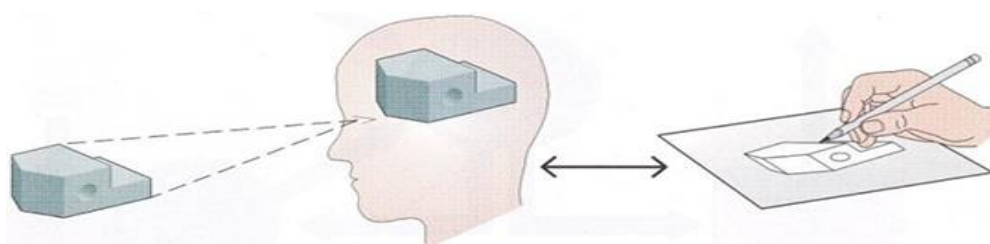

Figure 1. Brain eye.

Perception is a significant and fundamental piece of the building configuration process. Regardless of whether you are utilizing a PC or a great apparatus for specialized drawing, architects and technologists must be able to record their structure thoughts, based on well-defined specialized designs principles. They should likewise be able to comprehend at a profound level, three-dimensional structures and their documentation.

The capacity to imagine shapes as a primary concern upgrades the capacity of clients to see how existing offices, and offices that have not yet been brought about. Perception of three-dimensional shape permits the playing of the "imagine a scenario in which" in the beginning phases of the structure procedure, before framing the physical models. It likewise permits the capacity to imagine and nitty gritty spatial investigation of the event of any issues.

Designer or technologist ought to be expertly engaged with taking care of the issue. For most issues, it is important to pose some essential inquiries:

What data is accessible?

If it comes to realistic data, in which structure (planar drawing, photography, PC delivering, and so on.)?

What are the issues to be replied?

Is there adequate data (realistic or something else) to address these inquiries?

On the off chance that there isn't enough data, where to discover them?

As a rule, there isn't enough data. For this situation, counsel outer sources or imagining new thoughts. The data can likewise be created from past information. For the majority of the issues with video data that is the most ideal way. If there isn't enough graphical data is important to promptly begin drawing what is known. Presently starts the round of "consider the possibility that" wherein everything has a psychological picture, however there is enormous number of thoughts that are hard to remember. They are at the paper (or PC) and moving glorification procedure of confirmation and the procedure of fast summed up thoughts that are created in the brain.

How thoughts are created drawings are getting more formal. The custom is essential for correspondence with different clients.

This procedure is fundamentally the same as and in forming thoughts into three-dimensional space. Instruments are unique, yet the possibility of the development of the plan is the equivalent. At the point when you assemble all that is thought about the psychological development and the aftereffect of drawing/demonstrating, it is conceivable to picture a 3D item and keep on creating.

Building configuration show is an assortment of instruments that help originators and engineers to outwardly extend and spatially get ready fundamental plans, and furthermore that these arrangements are checked and shown to other people. During the assessment of plans, when an originator/engineer joins, looks at, handling and planning of assessment all things considered and calculated arrangements for the most part utilized freehand drawing instrument.

Streamline, the advancement period of this procedure includes characterizing thoughts in two stages: innovative work. In the improvement stage, the scientist deciphers your thoughts from the exploration period of the utilization of PC apparatuses (or, as the case was previously, when was being used realistic specialized devices of designing and specialized drawings and so forth.) in a last attainability study, used to assist correspondence in the system of the arrangement of the last item. Lately, theoretical stage is basically founded on freehand sketch, an advancement on the utilization of a product devices and PC mathematical displaying (Figure 2).

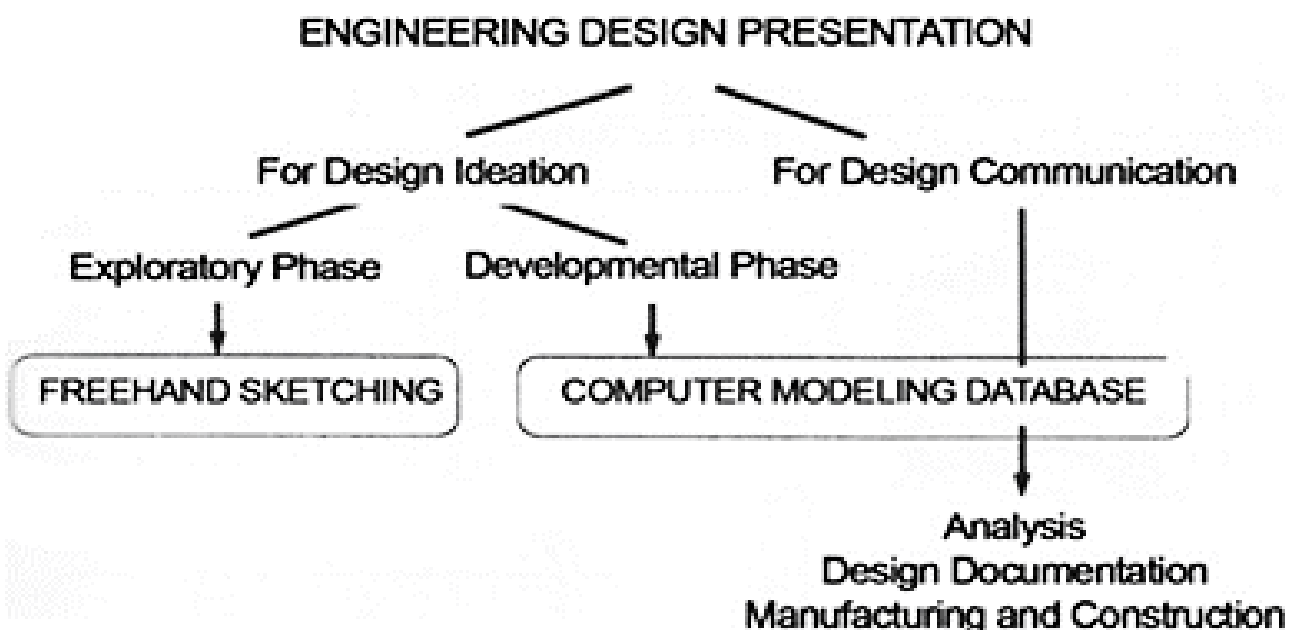

Figure 2. Engineering design presentations

Demonstrating is the way toward introducing theoretical thoughts, words and shapes, through the correct utilization of the rearranged text. Specialists use models for speculation, visual, correspondence, forecast, control and preparing. The models are grouped into two classifications: realty could be appeared on the elucidating or prescient way.

Descriptive model speaks to extract thoughts, items or procedures in an unmistakable structure. A case of a distinct model can be the designing drawing or a 3D PC model of the mechanical part (Figure 3). Drawing or model fills in as a specialized device, however they can't be utilized to foresee the conduct or execution acquiring specialized components/frameworks. The prescient model is one that can be utilized to comprehend and anticipate the conduct/execution plan arrangements, items or procedures. For instance, prescient limited component model is a model Cantilever, which is utilized to anticipate the mechanical conduct of the cantilever under the given burdens.

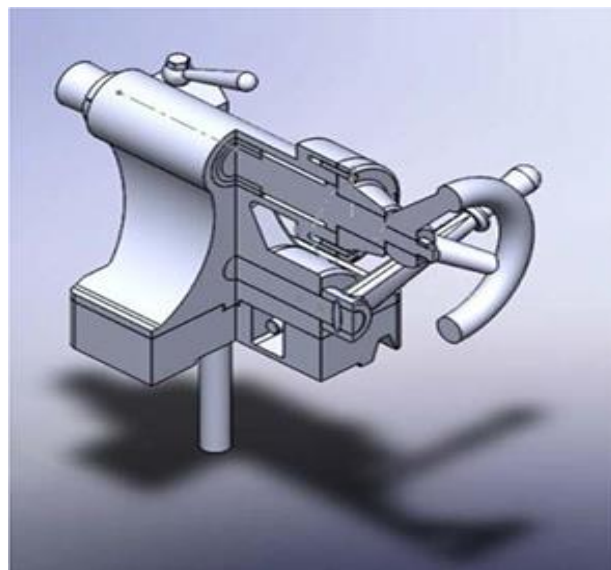

Figure 3. Descriptive model

During the preparation of the final product, it is possible to use two types of models: mathematical models and physics models-layouts. The mathematical model is a set of mathematical equations that represent parts of the system. Figure 4 is an example of the mathematical model used to predict the loss of power of thrust bearings while increasing speed.

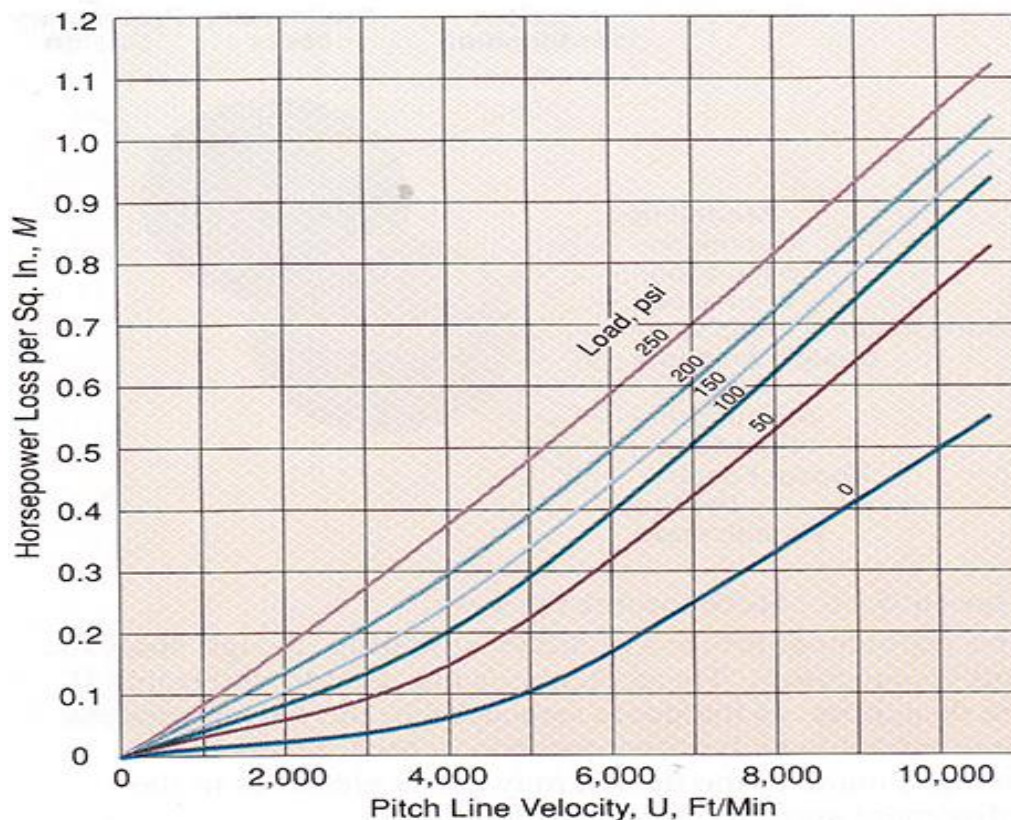

Figure 4.

Predictive model (example of a mathematical model; Machinery's Handbook, 25th edition). The model is a physical model created such that most dependably speaks to the pieces of a framework. Model might be full size, or reproductions made in the required (ideally standard) scale. Prior to the approach of PC 3D mathematical demonstrating, physical models are made of earth, wood, froth or different materials. The quick improvement of PC displaying caused fast arrangement of models and lessens the requirement for creation model genuinely, which depended on conventional procedures. This wonder is classified "fast prototyping" and speaks to a wide range of activities, which are utilized to portray a few related procedures, depending on genuine models that are taken straightforwardly from 3D CAD information base. As characterized over, this procedure can radically lessen the time between the advancement of an idea model and making the anticipated work. Mathematical demonstrating is a lot of procedures of complex thoughts, items or procedures, utilizing drawings or PC models rather than regular in configuration process. The last drawings got utilizing this technique were made as 2D and 3D plans or models.

Two-dimensional plans are extremely valuable for some building examination, for example, kinematic, and check the situation of circuit components, wiring charts and check the outlines, schematic perspective on certain parts and basic plans.

The next element of the educational model is based on reversible engineering. This is the one element that is required for each user: recording real technical elements/systems and data for further design and analysis. At this stage, the users are trained and that the data transmitted from technical drawings to the formation of the 3D model. Finally, education in the field of technical graphic communication comes to the stage of the formation of the entire technical elements/systems, to the coverage of all phases.

#### **LIST OF REFERENCES:**

1. Frederick E. Giesecke, Alva Mitchell, Henry C Spencer, et al. Modern graphics communication (Third Edition) [M]. American: Pearson Prentice Hall, 2004. 1-601
2. James H. Earle. Engineering Design Graphics (Sixth Edition). Addison-Wesley Publishing Company.
3. David A. Madsen. Engineering Drawing and Design. Delmar Publishers INC.
4. P.H. MILNE. Presentation Graphics for Engineering, Science and Business. An Imprint of Chapman & Hall
5. A.W. Boundy. Engineering Drawing (Fourth Edition). McGRAW-Hill Book Company Sydney.